

GAME DAY BUILDING POST TENSIONED STRUCTURAL REDESIGN



Matthew William Haapala

5th Year Penn State AE

Structural Option

Senior Thesis Final Report

Consultant: Prof. Hanagan

April 7th 2009

FOREMAN FIELD GAME DAY BUILDING NORFOLK, VA



Player Roster-

Owner: Old Dominion University
Gen. Contractor: S.B. Ballard Construction Co.
Architect: Ellerbe Becket
Engineer: Clark Nexsen

Overall Game Plan-

Gross Sq.-Ft.: 54,877
Height: 4 stories, 50 ft.
Cost: \$ 11.9 million
Game Time: Feb 2008 - Aug 2009
Delivery Method: Design-Build



Architecture-

The Game Day Building is an iconic addition to Foreman Field's existing facilities. It will house locker rooms, training facilities, restrooms, 24 luxury suites, additional premium seating, a scholarship lounge, a kitchen, and concessions. The building is clad in: brick, cast stone masonry, rubbed finish cast in place concrete, and glass curtain wall with ANOD. aluminum framing. Roofing is provided by EPDM roofing on insulation board supported by a 12" concrete slab.

Structural-

Gravity System- The 1st Floor is slab on grade. Floors 2-4 and the roof are supported by concrete flat plate slabs on concrete columns. Stadium seating is supported by curved concrete beams framing into sloped concrete girders.

Lateral System- 7 full height cast in place concrete shear walls connected by the rigid diaphragms of the floor slabs resist lateral loads.

Foundation- The building rests on square precast concrete piles and shallow spread footings

Lighting/Electrical-

Power- 480Y/277V system powers mechanical and lighting loads. 240Y/120V power is provided at recepticals. A diesel generator provides emergency power.

Lighting- Direct/Indirect troffers light the scholarship lounge. CFL cans light hallways. Direct troffers are used in all other spaces.

Construction-

Special Construction requirements include:
The project be completed in time for ODU's 2009 football season. The existing 1934 structure have lead paint and asbestos abatement. Resurfacing the field and reducing the existing 2 ft. crown.

Mechanical-

100% out door air handling units and VRV heat pumps provide heating and cooling to most of the building's conditioned spaces. A gas fired single-package roof top unit w/ return supplies the scholarship lounge. Electric unit heaters provide supplemental heating through the building.

MATTHEW W. HAAPALA
STRUCTURAL OPTION

WWW.ENGR.PSU.EUD/AE/THESIS/PORTFOLIOS/2009/MWH5005



TABLE OF CONTENTS

| | |
|---------------------------------------------------------|----|
| Executive Summary..... | 4 |
| Existing Conditions..... | 5 |
| Building Statistics | 5 |
| General Building Data..... | 5 |
| Architecture..... | 6 |
| Codes and Zoning | 6 |
| Fire Protection | 6 |
| Construction | 7 |
| Electrical | 7 |
| Lighting | 7 |
| Mechanical..... | 8 |
| Geotechnical..... | 8 |
| Existing Structural System Discussion..... | 9 |
| Foundations..... | 9 |
| Gravity System..... | 9 |
| Lateral System | 10 |
| Structural Depth Study | 11 |
| Problem Statement | 11 |
| Proposed Solutions..... | 12 |
| Reference Design Codes and Standards..... | 13 |
| Concrete Mixes..... | 13 |
| Gravity System Redesign..... | 14 |
| Loading Assumptions..... | 14 |
| Trial Layout and Member Sizes | 15 |
| PCA Slab Analysis and Design | 17 |
| Post Tensioned Beam Design Theory | 19 |
| Post Tensioned Beam Design Hand Calculation Method..... | 21 |
| RAM Concept Analysis and Design | 22 |

| | |
|--------------------------------------------------------|----|
| Lateral System Redesign | 27 |
| Wind Loading..... | 27 |
| Seismic Loading | 29 |
| Overall Lateral System Design | 30 |
| Lateral System Performance under Wind Loading..... | 35 |
| Lateral System Performance under Seismic Loading | 36 |
| Beam Design for Lateral Loading..... | 37 |
| Shear Wall Design | 38 |
| Column Design..... | 40 |
| Foundation Redesign..... | 41 |
| Structural Depth Conclusions..... | 45 |
| Breadth Studies..... | 46 |
| Construction Management Breadth | 46 |
| Problem Statement | 46 |
| Proposed Solution | 46 |
| Cost analysis | 46 |
| Schedule Analysis | 47 |
| Construction Management Breadth Conclusions | 51 |
| Lighting Breadth Study | 52 |
| Problem Statement | 52 |
| Proposed Solution | 52 |
| Lighting Plan and Fixture Schedule..... | 53 |
| Quantitative Design | 54 |
| Renderings..... | 55 |
| Lighting Breadth Conclusions | 57 |
| Masters Level Class Influence | 57 |
| Conclusions | 58 |
| Acknowledgmetns..... | 58 |

Appendices..... 59

 Appendix A Structural 59

 Appendix B Construction Management..... 67

EXECUTIVE SUMMARY

The Forman Field Game Day Building is a football stadium grandstand currently being constructed for Old Dominion University on their Norfolk, VA campus. The Game Day Building is the centerpiece of renovations to the existing 1934 Foreman Field stands in preparation for the fall 2009 football season, Old Dominions University's first in nearly 70 years.

This document is a report that analyzes the effects of changing the Game Day Building's floor system from a two-way reinforced concrete flat plate to one-way reinforced concrete slabs supported by post tensioned concrete beams. The primary results of changing the floor systems determined in the report are that the typical slab depth can be reduced by five inches, that the addition of beams to the floor system allows the removal of four of the seven shear walls, and twenty five of the 183 piles supporting the structure can be removed.

In addition to the structural design implications, the effects of incorporating post tensioned beams into the floor system on the Game Day Building's construction costs; schedule and a new lighting configuration it makes possible were studied.



EXISTING CONDITIONS

Building Statistics

General Building Data

Building Name: Foreman Field Game Day Building

Building Occupant Name: Old Dominion University Monarchs

Location: The Game Day building is currently under construction in the south end zone of Foreman Field on the campus of Old Dominion University in Norfolk Virginia.

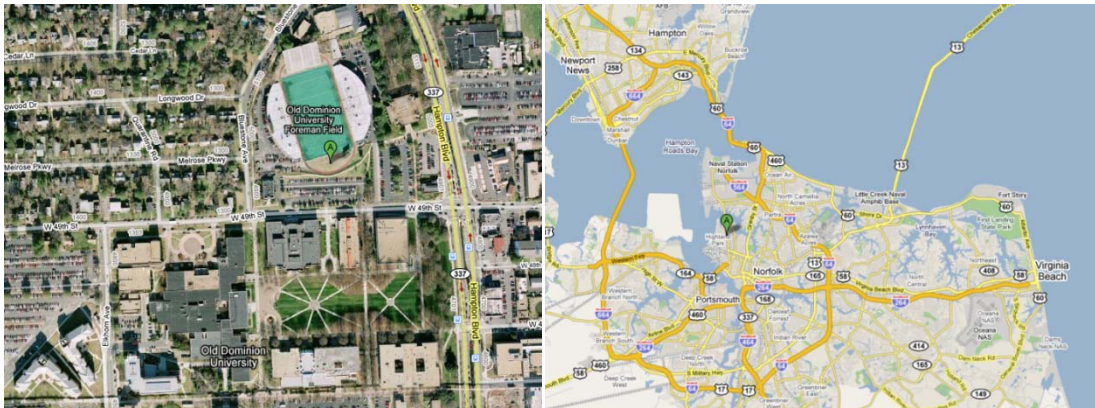

Figure 1

Size: Gross Floor Area = 54,877 sq. ft.

- 1st Floor = 16,473 sq. ft.
- 2nd Floor = 16,143 sq. ft.
- 3rd Floor = 11,499 sq. ft.
- 4th Floor = 10,762 sq. ft.

Height = 47'

Primary Project Team:

- Owner- Old Dominion University
- General Contractor- S.B. Ballard Construction Company
- Architect- Ellerbe Becket
- Engineer- Clark Nexsen

Dates of Construction: February 22, 2008 thru July 22, 2009

Cost: \$11.9 million

Project Delivery Method: Design-Building

Architecture

The Project's architect is Ellerbe Becket who has an impressive portfolio of sports venue projects nationwide. The Game Day Building is a four story tall, 55,000 sq. ft., partially enclosed grandstand. The first floor is comprised of locker room and training facilities, coaching offices, concessions, and restrooms. The 2nd floor has mini-box seating, a kitchen, a scholarship lounge, and additional restrooms and concession stands. The 3rd and 4th floors have 12 luxury suites each and additional rooms such as sound, lighting, and scoreboard control rooms. The majority of the façade is clad in brick masonry with cast stone trim. The remainder of the building is clad with cast stone masonry, a storefront glazing curtain wall system with anodized aluminum mullions, or rub finished cast in place concrete. The south face of the building is accentuated by five one story and one three story entry archway clad in cast in stone masonry adorned with two aluminum flag poles. The cantilevered balconies with seating, large areas of glass curtain wall, and a scoreboard distinguish the north façade. The roofing system consists of a 12" concrete slab topped with EPDM roofing membrane over polyisocyanurate insulation board.

Codes and Zoning

The Building was designed in accordance with 2003 (VUSBC) Virginia Uniform Standard Building Code an amended version of the 2003 IBC. Most of the building is classified as A3 or A5 Assembly Occupancy with a small portion classified B Business Occupancy. The site is zoned as (IN-2) an Institutional Campus District by the City of Norfolk, Virginia. This zoning is intended to accommodate the unique multi-function needs of universities and permits all the Game Day Building's classifications.

Fire Protection

A dry type automatic sprinkler system and horn/strobe units on all floors provide fire protection. The Primary fire construction type is IIB with approved automatic sprinkler system throughout per IBS 903.3.1.1. The subsequent minimum fire resistance ratings according to IBC Table 601 are as follows.

| Building Component | Required Fire Rating |
|---------------------------|-----------------------------|
| Structural Frame | 0 Hr. |
| Bearing Wall (EXT.) | 0 Hr. |
| Bearing Wall (INT.) | 0 Hr. |
| Non-Bearing Wall (EXT.) | 0 Hr. |
| Floor Construction | 0 Hr. |
| Roof Construction | 0 Hr. |
| Shaft Enclosures | 2 Hr. |

Figure 2

This results in the only required use of fire rated walls being two hour walls around stairwells and utility shafts. Additionally 30 minute rated separations are provided between individual suites on the 3rd and 4th floors. The roof covering fire classification is Class "C" per IBC Table 1505.1. Accessible egress is considered provided by elevated walkways connecting to the accompanying parking garage which has an elevator and the two main stairwells.

Construction

The General Contractor is the S.B. Ballard Construction Company. In addition to the Game Day Building, S.B. Ballard has been named the general contractor for multiple other recent projects on ODU's campus. The Construction is being carried out from February 2008 thru July 2009 for an estimated cost of \$11.9 million. The project delivery method is a design-build contract. Project completion deadline is very important as the Old Dominion Monarchs are scheduled to host the Chowan University Hawks at Foreman Field on Sept. 5, 2009. Being ODU's first football game in nearly 70 years it will be highly anticipated and publicized. In addition to the Game Day Building the Foreman Field restoration project includes a new precast concrete parking structure, which has been completed ahead of schedule and restoration of the existing 1934 stadium, which includes lead paint and asbestos abatement.

Electrical

Power is supplied at 480V to the building through one of two separately metered distribution panels in a main switch board in the accompanying parking garage. This panel feeds high voltage panels and 112.5KVA to 150KVA, 480V 3 phase 3 wire- 208Y/120 3 phase 4 wire, step down transformers. The Lighting and some of the HVAC equipment is run at 480Y/277V off the high voltage panels. The remainder of the equipment and receptacles run on 208Y/120V on low voltage panels fed by the step down transformers. A 175kw, 480Y/277 diesel engine generator provides backup power for emergency lighting, medical equipment, elevator equipment, walk-in coolers and freezers, and some minimal HVAC systems.

Lighting

The overall building lighting scheme is fairly simple. Locker rooms, offices, restrooms, concessions, and other service areas are lit with a combination of recessed and ceiling mounted direct florescent troffers. Public egress spaces are lit with compact florescent cans. The Scholarship Lounge intended for yearlong use for receptions and other publicity functions utilizes direct/indirect luminaires for a more upscale appearance. The Lighting system is powered by 277 Volt circuits. Exterior lights are automatically controlled by both a timer and a light sensor on the roof. Some Interior lights are attached to a day lighting system controlled by exterior mounted photocell light detectors on the north face of the building.

Mechanical

On the first floor the locker rooms and training facilities are served directly by one of two 100% outdoor air-handling units located on the Game Day Building's roof. Supplemental heating is provided to these spaces by electric unit heaters located throughout the rooms. The upscale scholarship lounge on the second floor is supplied by a gas fired single-package roof top unit, which utilizes the only return air system in the building. The kitchen's mechanical system consists of a "Make-Up" air unit with gas fired heating capabilities and several exhaust hoods. The second 100% outdoor air handling unit supplies a series of variable refrigerant heat pumps that provide additional heating and cooling of the air supplied to diffusers in the 3rd and 4th floor suites, control, recruiting, and group sale rooms. The remaining spaces in the building such as restrooms, concessions, utility rooms etc., are heated and cooled by zone DX split system heat pumps or electric unit heaters. Ventilation in these areas is only directly dealt with by exhaust ducts in restrooms and the pantries. The hallways throughout the building are not conditioned spaces.

Geotechnical

The entire site's subsurface soils are comprised of a combination of wet sands and clays with low load bearing capacities. Therefore, a deep foundation system is required to achieve the required bearing strengths. The water table was found to be approximately six feet below current grade. The following table summarizes the boring test results across the site.

| Sub-Surface Soil Conditions | |
|------------------------------------|-------------------------------------------------------------------------------------|
| Average Depth (ft.) | Description |
| 0 to 1 | Topsoil or Asphalt |
| 0 to 4 | Fill of fibrous organics and wet sand |
| 2 to 18 | Sand with varying amounts of silt and clay |
| 18 to 53-84 | Gray, wet clay with varying amounts of sand and marine shell fragments |
| 53-84 to 110 | Gray, wet, silty, fine sand with marine shell fragments and varying amounts of clay |

Figure 3

Existing Structural System Discussion

Foundations

Forman Field Game Day Building rests primarily on square precast prestressed concrete (SPPC) piles. The subsurface soil conditions across the site are a combination of wet sands and clays down to a depth of 110 ft. The soil conditions necessitate a deep foundation of friction type piles to achieve required bearing capacities. A total of 185 (SPPC) piles, all 12" wide and 100' long from tip to cutoff, are located below columns and shear walls in singles and clusters of up to 18. Individual piles have capacities of 85 tons in axial compression, 40 tons in axial tension and 5 tons in lateral resistance. The piles are topped with 36" to 40" deep pile caps. Grade beams are run between pile caps to provide stability to one and two pile clusters and continuous support below the exterior facade walls. A half wall on the east side of the ground floor is supported by spread footings designed to bear on soil with an allowable bearing pressure of 1500 psf.

Gravity System

The Game Day Building's typical floor system is a 12" deep reinforced concrete flat plate slab. #5 reinforcing spaced between 3.5" to 12" on center both top and bottom is used to reinforce the flat plate slab. A typical bay size is 31'-6" by 17'-0". In plan a majority of the building is a shallow curve with column lines being radial spokes in the short direction and curves at set radii in the long direction. This leads to many bays not being exactly rectangular. Embedded three foot long shear rails in both directions at every column corner except along the slab edges provide additional shear capacity to combat punching shear. The slabs are held up by the columns and load bearing walls. Columns are typically 16"x16", with eight #7 vertical bars and #3 ties at 12" on center. Most of the roof is also 12" concrete flat plate with typical reinforcement. The first floor is a 4" deep reinforced slab on grade. Some atypical areas are the bleacher seating area and the kitchen roof. The stepped down seating area on the north side of the second floor is supported by concrete beams and raked girders. The kitchen roof is made and supported by cold formed steel framing.

Lateral System

Seven, building height, reinforced concrete shear walls are designed to provide the building’s lateral stiffness. They are reinforced with two curtains of #5 rebar at 12” on center for shear resistance. Flexural reinforcement is provided by 2 #6 to 7 #9 vertical rebar varying between walls and decreasing with height within a wall. No boundary elements were used in the shear wall flexural design. Additional vertical, horizontal, and diagonal rebar is located surrounding openings cut through the shear walls for M.E.P ducts and doorways. The Game Day Building is designed so that lateral loads flow from the façade into the 12” slabs on every floor which act as rigid diaphragms distributing the load amongst the seven shear walls based on relative stiffness. The shear walls all rest directly on pile caps or grade beams between pile caps. Several piles per shear wall are ‘tension piles’ with broom ends of prestressing strands extending into the pile caps allowing them to take tension load and resist overturning moment. The lateral stiffness inherently present in the frame formed by the columns and slabs was neglected in the design of the buildings lateral system.

Shear Wall Location Plan

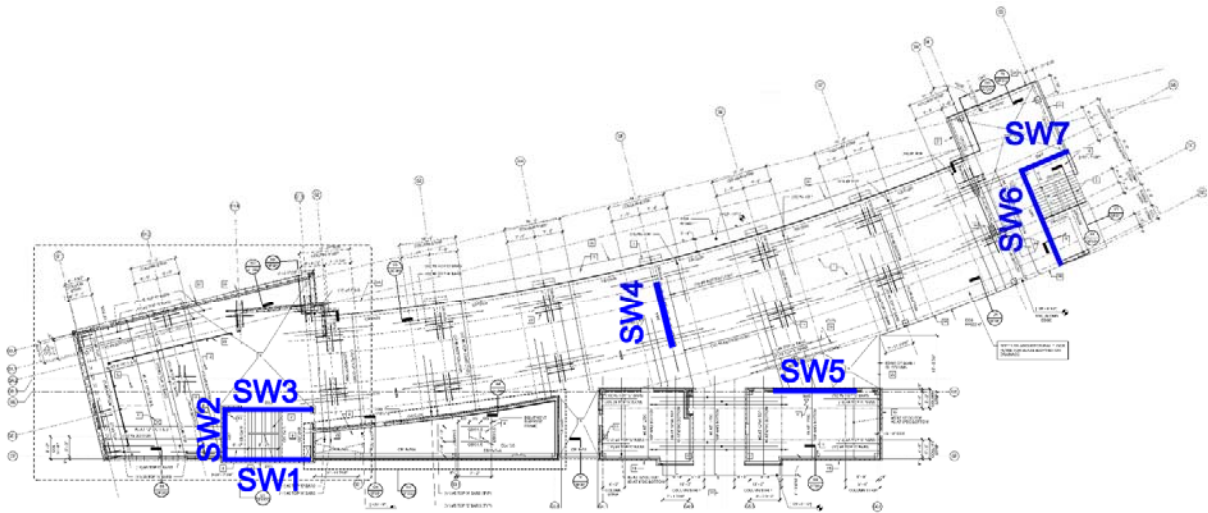

Shear Walls are in Blue

Figure 4

STRUCTURAL DEPTH STUDY

Problem Statement

Problem 1:

A uniform slab depth was an architectural requirement imposed on original designers. Based on this requirement they selected to use a reinforced concrete two-way flat plate for the Game Day Building's floor system. While a two-way flat plate was an ideal structural solution to satisfy this requirement it is not necessarily the optimal structural system if this requirement is not enforced.

The Game Day Building has a very slender curved rectangular shape reflected in its column grid. This results in the typical bays having aspect ratios between 2:1 and 4:1. Due to this rectangular geometry loads are inclined to be distributed as if in a one-way floor system. Therefore, a two-way flat plate floor system which is designed based on a two-way load distribution will inherently not provide the most structurally efficient use of materials.

Problem 2:

As a 47' tall reinforced concrete building, located in a seismically inactive region, effects of lateral loads are not a preeminent design concern for the Game Day Building. The existing lateral system is comprised of seven, cast in place, concrete shear walls. The shear walls are located in architecturally prudent locations such as around the stairwells.

An effect of the Game Day Building's oblong plan dimensions is that much higher magnitudes of wind loads are imposed on the lateral system from the North and South than from the East or West. The weight of the 12" thick concrete floor slabs, poor soil conditions, and short period produces seismic loads of similar magnitude to the factored wind loads.

The existing lateral system analysis documented in Tech Report 3 determined that as designed the Game Day Building's lateral system has excess capacity in flexural strength shear strength and stiffness. The amount of excess capacity is greater in the East/West plan direction due to the lower wind loads.

Problem 3:

The poor soil capacity on site dictates that the only practical foundation solution is the use of friction type piles. The large number of piles required to support the building's weight constitute a substantial portion of the structural system cost and erection duration.

Proposed Solutions

Structural Study 1:

The two-way flat plate system will be redesigned as a system comprised of one-way reinforced concrete slabs supported by post tensioned concrete beams.

- Determine possible reductions in slab depth by using one-way slabs spanning across the short direction of bays
- Minimize increase in total floor system depth by using wide shallow post tensioned beams to supporting the one way slabs
- Develop an in-depth understanding of the structural design procedure of post tensioned concrete
- Create a more structurally efficient floor system by utilization of high strength materials and post tensioning

Structural Study 2:

The lateral system will be redesigned by reducing the number of shear walls as much as possibly when the stiffness provided by the inherent ordinary concrete moment frames and the excess capacity of the shear walls in is considered.

- Utilize post tensioned beams in ordinary concrete moment frames
- Reduce the number of shear walls

Structural Study 3:

The building foundations will be analyzed based on the redesigned lateral and gravity systems. Based on the analysis results the number of piles shall be reduced as much as possible without significant increases in the shallow foundations.

- Reduce the number of piles as much as possible by taking full advantage of the redesigned gravity and lateral systems.

Reference Design Codes and Standards

The proposed structural redesigns were designed in accordance with 2006 IBC and the most current national material reference standards as of Jan 1, 2009. Figure 5 below lists the codes and reference standards used in both the original and redesigned structure.

| Reference Design Codes and Standards | |
|-----------------------------------------------|---------------|
| Original Design Code | Substitutions |
| 2003 Virginia Uniform Statewide Building Code | 2006 IBC |
| ASCE 7-02 | ASCE 7-05 |
| ACI 318-02 | ACI 318 08 |

Figure 5

Concrete Mixes

The concrete used on the above grade structure was changed from 5000 psi concrete to 6000 psi high early strength concrete. This change increases design flexibility by increasing the concrete modulus of rupture and compressive strength and thus the tensile and compressive stress limits for post tensioning. By changing the cement from a type I to a type III high early strength, the slab will reach f'_{ci} faster allowing the tendons to be tensioned sooner and thereby help mitigate the increased duration post tensioning adds to the schedule.

| Concrete Material Properties | Original | | New | |
|------------------------------|-----------|-------------|-----------|-------------|
| | f'c (psi) | Cement Type | f'c (psi) | Cement Type |
| Pile Caps and Grade Beams | 3000 | I | 3000 | I |
| Slabs on Grade | 3000 | I | 3000 | I |
| Structural Slabs and Beams | 5000 | I | 6000 | III |
| Walls and Columns | 5000 | I | 6000 | III |

Figure 6

Gravity System Redesign

In order to redesign the Game Day Building's gravity system to incorporate post tensioned beams a combination of hand method calculations in Microsoft Excel, and computer models in PCA Slab, PCA Column, and RAM concept were used. The following procedure was used to design all members of the structure to resist gravity loading.

1. Create initial beam and slab layout and trial member sizes
2. Design slabs in PCA Slab
3. Design post tensioned beams in excel using hand calculations
4. Check design results and adjust as required in RAM concept model analysis

Loading Assumptions

Dead loads were assumed to be comprised of structure and facade self weight. Additionally, mechanical equipment weights and a five-pound per square foot blanket allowance for MEP ducts, electrical conduit, etc., were taken as superimposed dead loads. Due to the assembly occupancy of the structure live load reductions were not used in either the original design or proposed redesigns.

| GRAVITY LOADING DESIGN VALUES | | |
|---------------------------------------|---------------------|------------------------|
| Loading | Design Value | ASCE 7-05 Req'd |
| Dead Loads | | |
| Normal Weight Concrete | 150 pcf | |
| Masonry Walls | 40 psf | |
| Curtin Walls | 15 psf | |
| Mechanical/Electrical/Plumbing | 5 psf | |
| 100% Outdoor Air Handling Unit | 750 lbs | |
| Variable Refrigerant Volume Heat Pump | 350 lbs | |
| Gas Fired DX Package Roof top Unit | 500 lbs | |
| DX Split System Heat Pump | 250 lbs | |
| Live Loads | | |
| ROOF | 20 psf | 20 psf |
| STAIRS | 100 psf | 100 psf |
| CORRIDORS | 100 psf | 100 psf |
| TERRACES | 100 psf | 100 psf |
| SEATING | 100 psf | 60 psf |
| STORAGE | 125 psf | 125 psf |
| MECH./ELEC. ROOMS | 125 psf | |
| Snow Loads | | |
| Pg | 10 psf | 10 psf |
| Pf | 11 psf | 11 psf |

Figure 7

Trial Layout and Member Sizes

Starting with straight lines between all adjacent existing columns possible beam locations were narrowed down to a trial design. The objectives guiding this process were:

- Minimize column relocation
- Slab spans of similar distance to allow for consistent shallow slab depth
- Relatively straight continuous beam spans to allow for continuous tendon strips
- Tendon strips not exceeding 250' to avoid friction loss and shrinkage problems

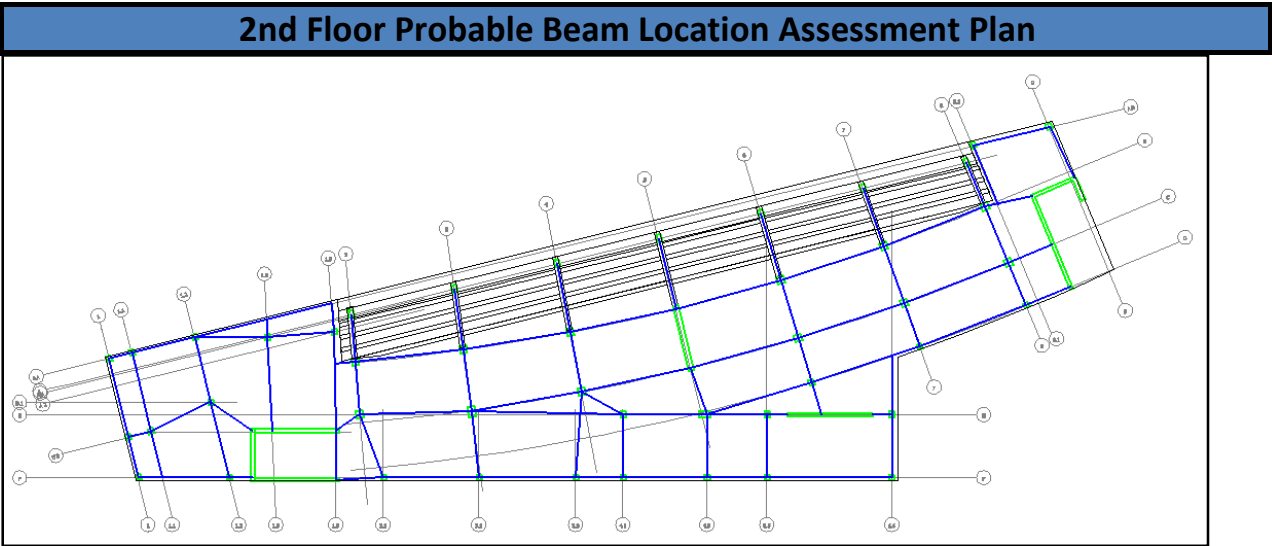

Figure 8

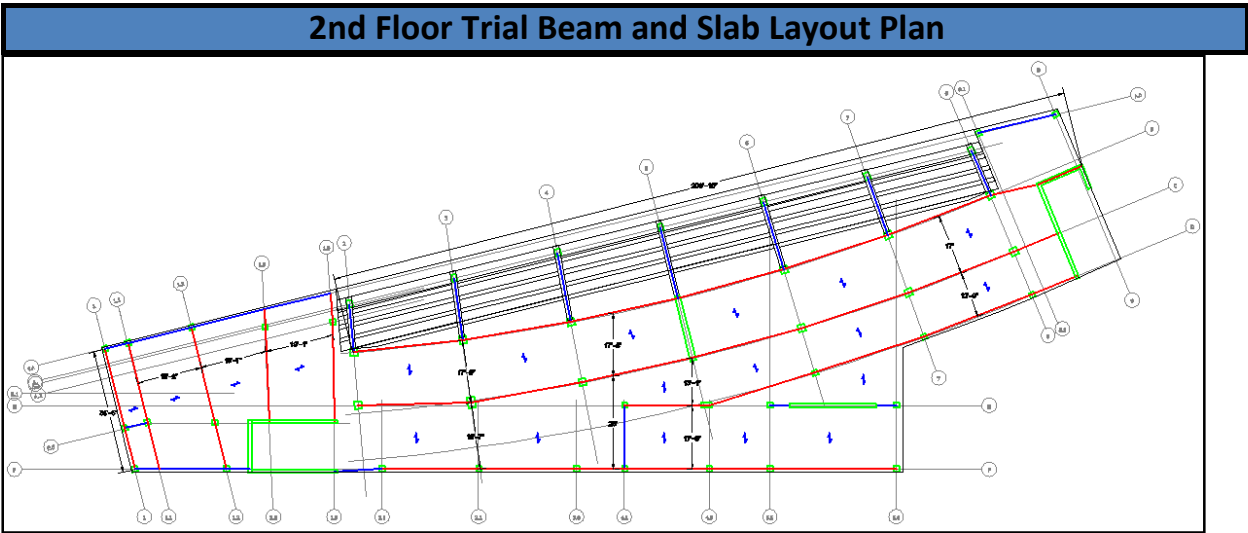

Figure 9

- = Post Tensioned Concrete Beam
- = Reinforced Concrete Beam
- = Support Column or Wall

Trial Member sizes were based on ACI 318-08 table 9.5 recommended span/depth ratios for deflection control and column widths.

For one-way slabs with both ends continuous

$$(h_{\text{slabMIN}}) = L/28$$

Assuming $L_{\text{Typ}}=15'$

$$h_{\text{slabMIN}} = (17' * 12''/') / 28 = 7.28'' \rightarrow h_{\text{slab}} = 7''$$

For cantilevered one-way slabs

$$(h_{\text{slabMIN}}) = L/10$$

Assuming $L_{\text{Cant Typ}} = 9'-6''$

$$h_{\text{slabMIN}} = (9.5' * 12''/') / 10 = 11.4'' \rightarrow h_{\text{slab}} = 12''^{**}$$

** Edge beams required to reduce slab thickness on cantilevers

For Beams with both ends continuous minimum beam thickness

$$(h_{\text{BeamMIN}}) = L/21$$

Assuming $L_{\text{Typ}}=31.5'$

$$h_{\text{BeamMIN}} = (31.5' * 12''/') / 21 = 18 \rightarrow h_{\text{Beam}} = 24''$$

Trial Typical Beam Size 18"x24"

Using these trial sizes the 2nd floor was modeled in RAM Concept. Unfortunately nearly every member failed in multiple ways. RAM Concept user interfaces is cumbersome and the program must rerun calculations for the entire frame, a time consuming procedure, whenever any design variable is changed for the result to be valid. Based on the numerous errors and large number of design variables associated with post tensioned concrete design it was decided to perform more accurate hand calculations to develop better designs before proceeding further in RAM Concept.

PCA Slab Analysis and Design

Slab unit strips continuous over beams in several locations throughout the building were analyzed in PCA slab using a 7" thickness and the trial beam layout. A slab depth of 7" proved sufficient for flexural and shear capacity but not necessarily for long-term deflections. The unit strips were repeatedly rerun as the design of the beams supporting them was updated until the deflection problems were eliminated. Figures 10 and 11 show this process for one design strip.

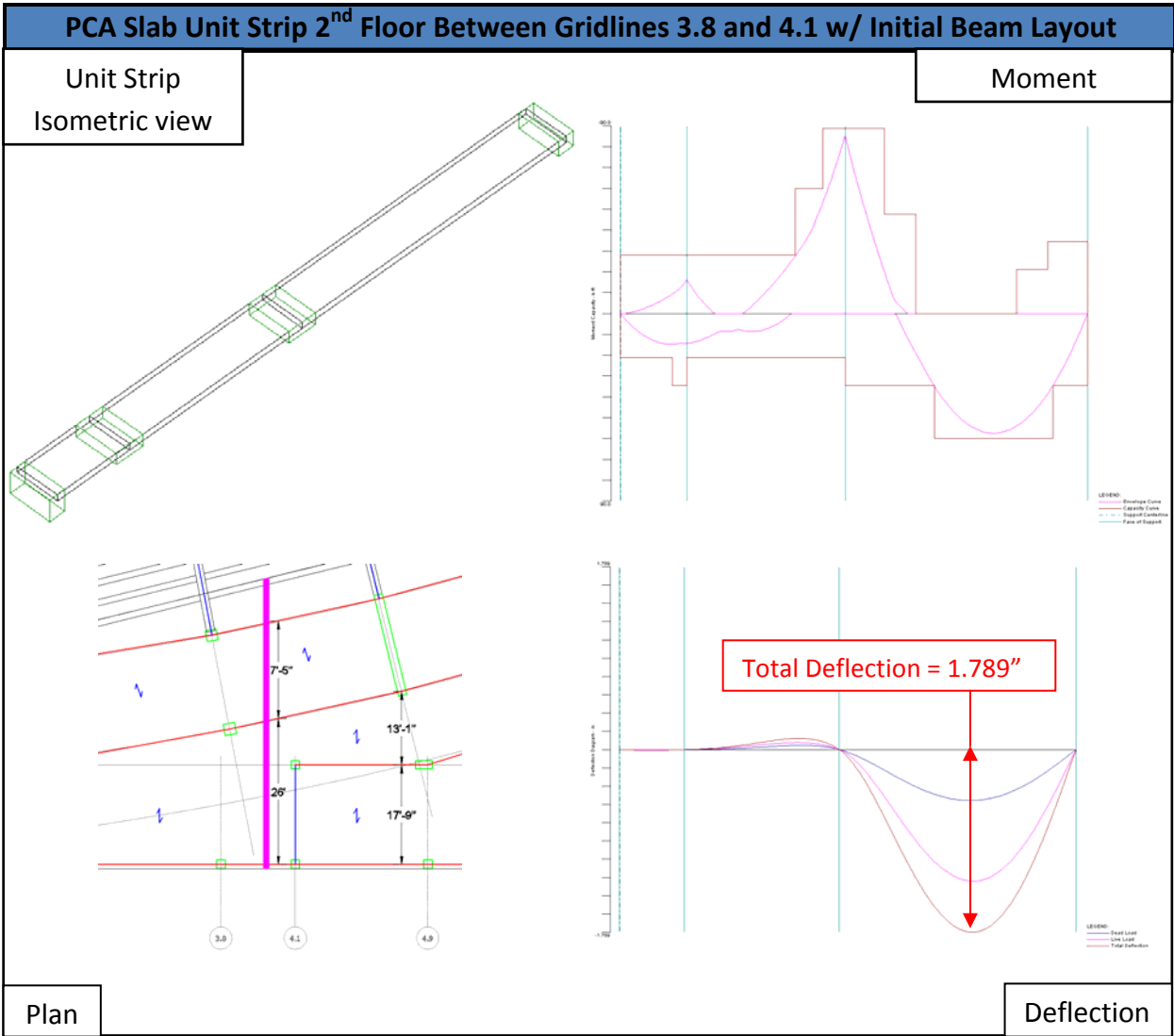

Figure 10

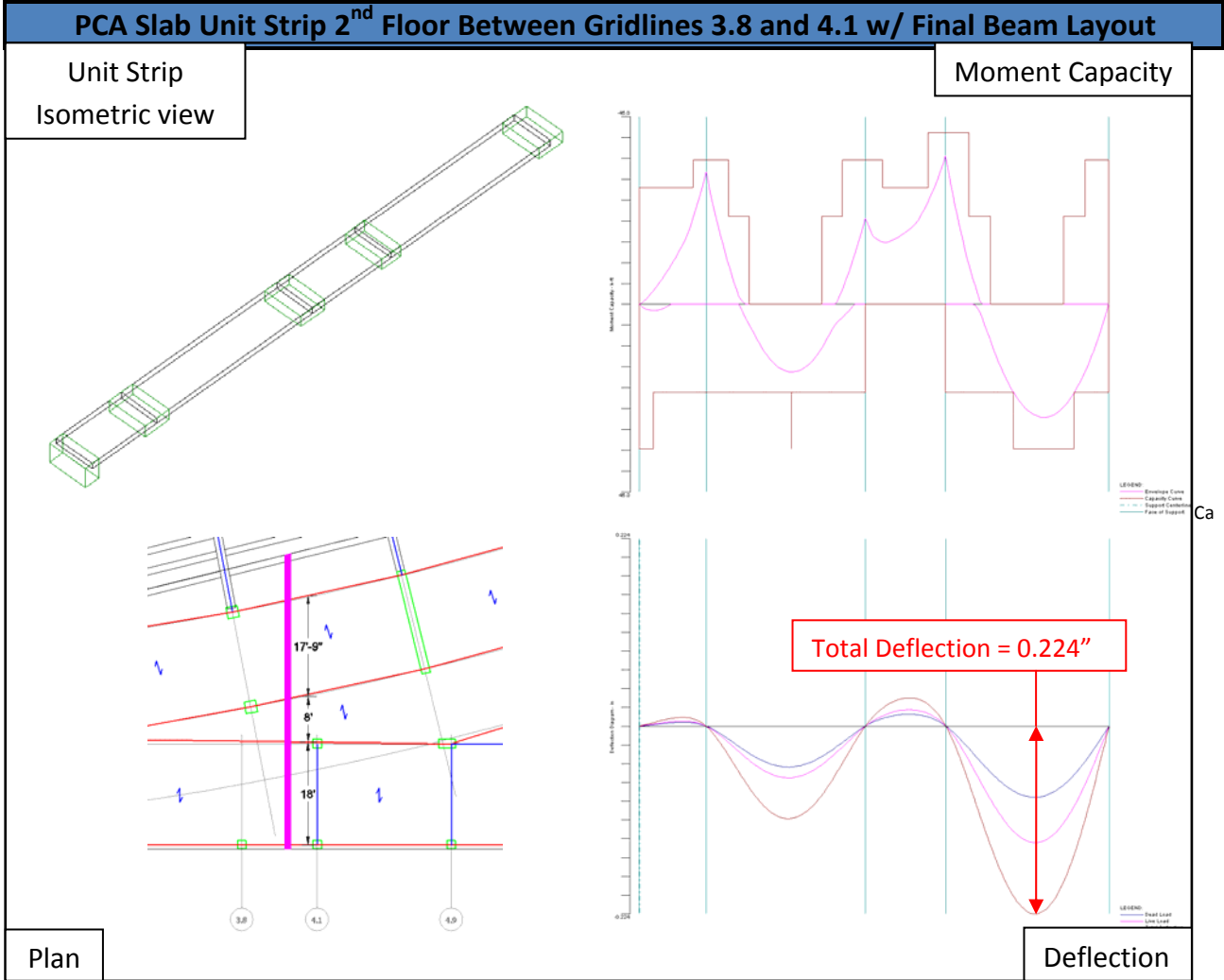

Figure 11

Post Tensioned Beam Design Theory

Concrete although very strong in compression has very little strength in tension. Because of this, in normally reinforced concrete design, the area of concrete in tension is assumed cracked and completely neglected when determining a beams flexural capacity. It is not rare to have less than 20% of the cross section contribute. If however an axial compressive force is applied to the section the entire member can be in compression under combined bending and axial loading and thus 100% of the concrete section can be considered in design.

In post tensioned concrete design such an axial load is applied as follows. Before the concrete is poured, high strength steel tendons covered in a greased plastic sheathing are placed along the length of the beam and extend beyond the limits of the pour on at least one end. Then the concrete is poured and is allowed to cure to a compressive strength of at least around 3000psi. Once the concrete has reached sufficient strength, the ends of the tendons extending beyond the poured beam are tensioned by jacks up to a specified elongation. The tendons are permanently kept in tension by being locked into their elongated state by steel anchorages. These anchorages in turn apply a compressive axial load on the concrete beam. Detailed anchorage zone design is beyond the scope of this report.



Figure 12

When the tendon is eccentrically located below the centroid of the beam it creates a moment that makes the member want to camber. This camber counteracts part of the deflection due to gravity loading. In other words tendon eccentricity can be considered to balance part of the gravity load. An ideal tendon profile to take advantage of balancing moments is a parabolic drape between supports. A sufficiently accurate approximation of the effects a parabolic tendon profile is a uniformly distributed upward force. Figures 13 to 16 below depict the effects of tendon profile.

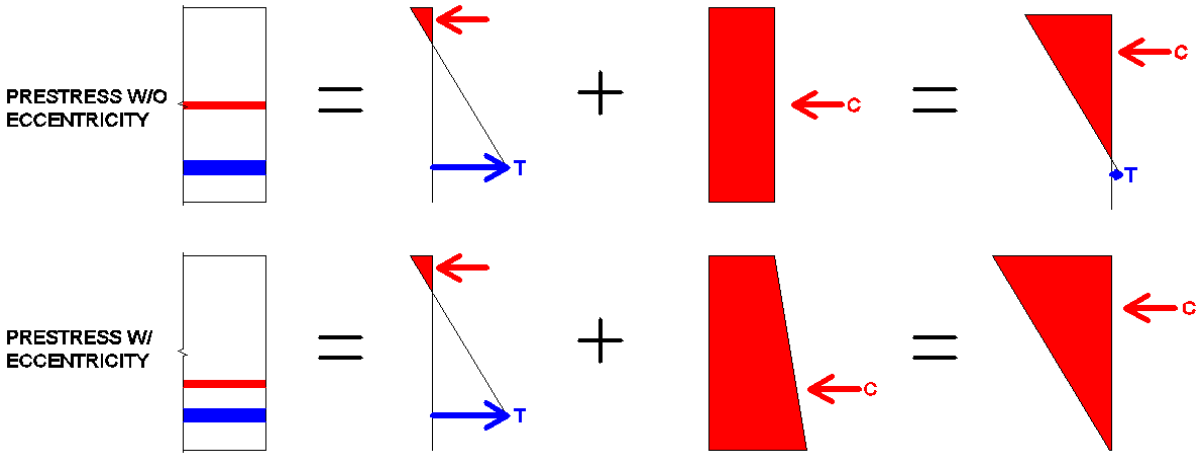

Figure 13

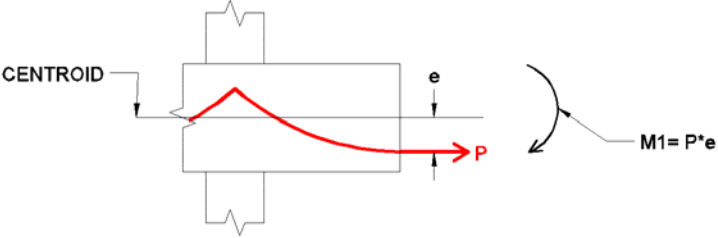

Figure 14

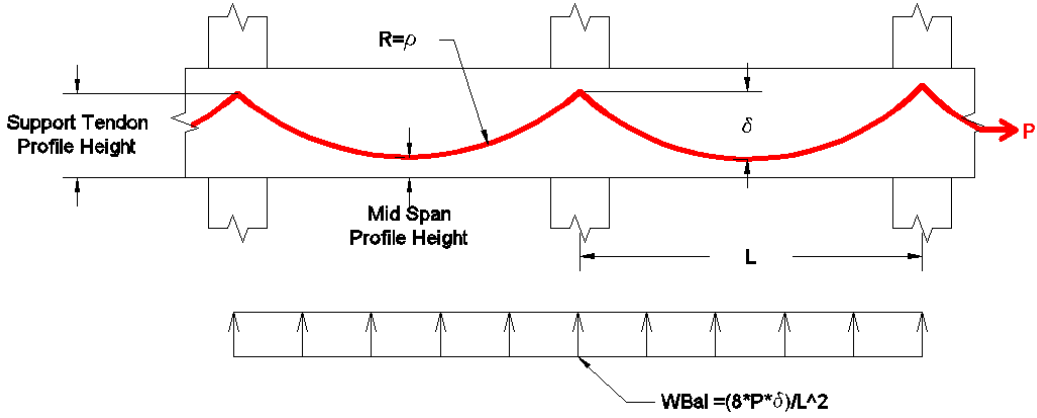

Figure 15

In beams continuous over multiple supports the cambering effect of eccentric prestressing has secondary effects. In order to maintain displacement continuity reaction moments are generally referred to as secondary moments.

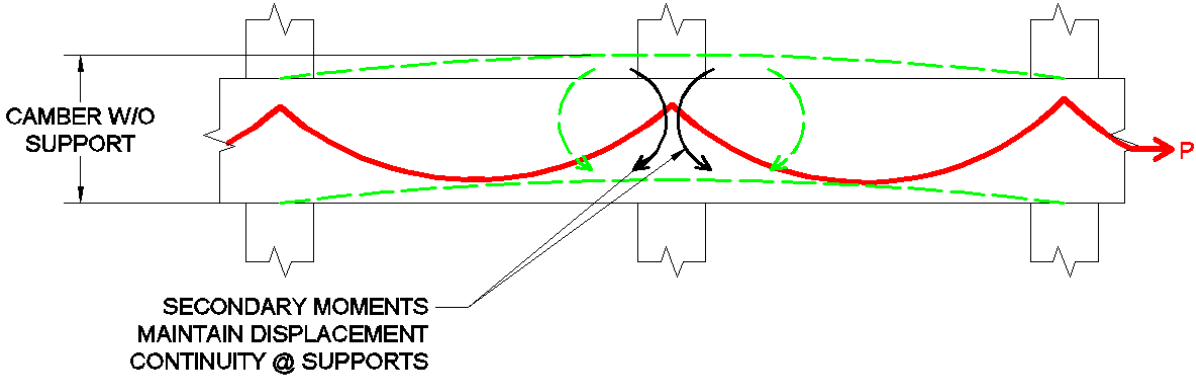

Figure 16

Post Tensioned Beam Design Hand Calculation Method

To expand upon the fundamental principals described in the previous section a Microsoft Excel file was programmed to design all aspects of continuous post tension beams. Using Prestressed Concrete Analysis and Design Fundamentals Second Edition by Antoine E. Namman as a reference, all post tensioned beams were designs in full compliance with ACI 318-08

The Excel file was designed so that by a imputing a very limited number of variables such as span, beam cross section, superimposed area loading, and the number tendons in the beams an iterative moment distribution calculation accurately determined all design shears and moments for each member at its supports and mid-span. All members were automatically checked for compliance with all ACI 318-08 code prevision for flexural serviceability requirements, ultimate flexural strength, shear, torsion, and deflection. If a beam was found in violation of a code provision such as having a tensile stress in excess of $0.6f'_{ci}$ immediately after jacking, not satisfying a minimum spacing requirements, or not having sufficient ultimate moment capacity, the violation was instantly flagged in red. This feature allowed for quick visual inspection of a beam designs strengths and weaknesses instantly. Tabulated design calculations for the post-tensioned beams on the second floor can be found in Appendix A. Calculations for the other floors are available upon request. The figures below are of a 28"x14" beam with six tendons, one of the most common designs determined with Excel.

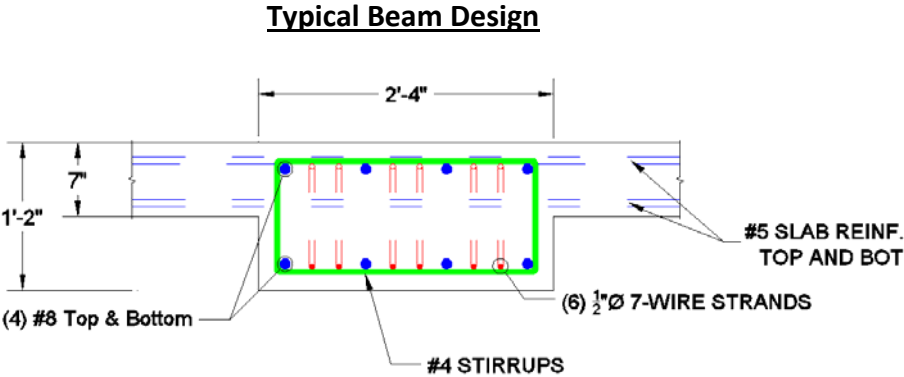

Figure 17

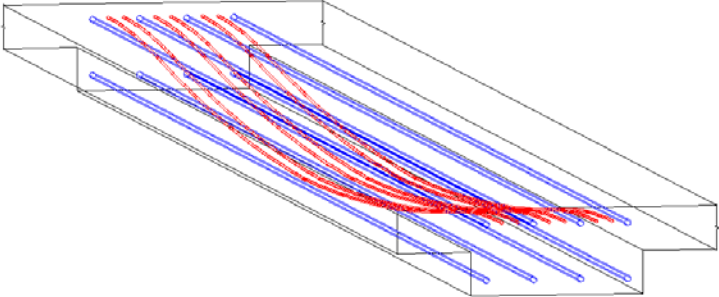

Figure 18

RAM Concept Analysis and Design

After all post tensioned beams had successfully been designed in Excel for flexure, shear, and deflection and slabs had been designed in PCA Slab; A RAM Concept model of the redesigned floor systems was created. Unlike the model based on the initial trial members, where nearly every member failed in multiple ways, only torsion and deflection related failures were present. RAM concept models were created of all four elevated floors to design for the unique geometries on each floor.

Second Floor Tendon Profile Perspective

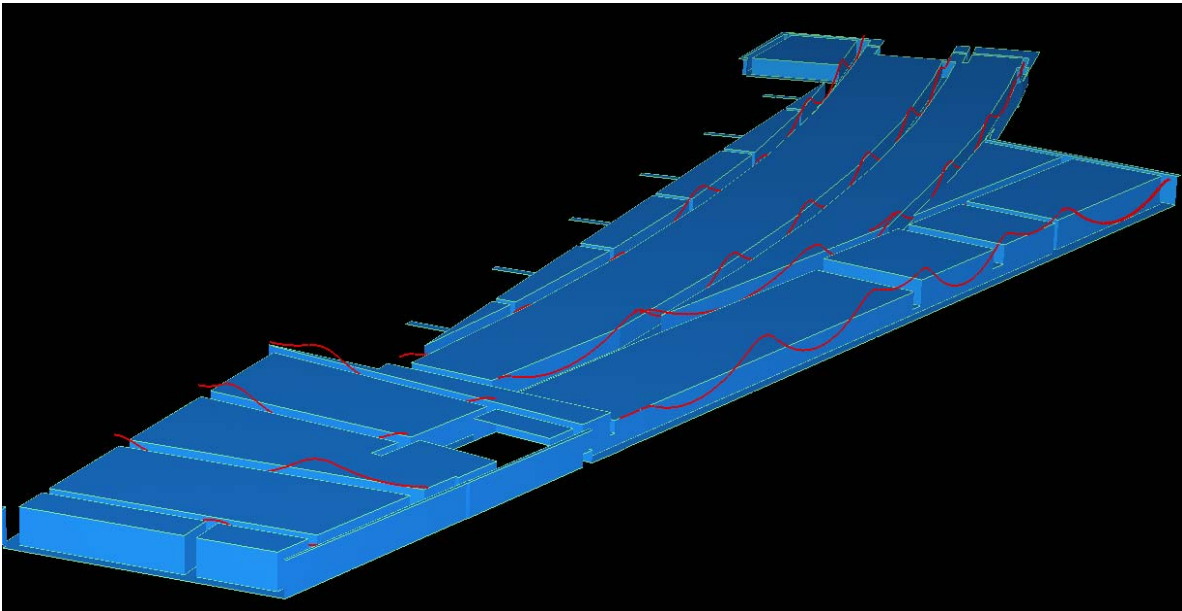

Figure 19

Second Floor Element Perspective

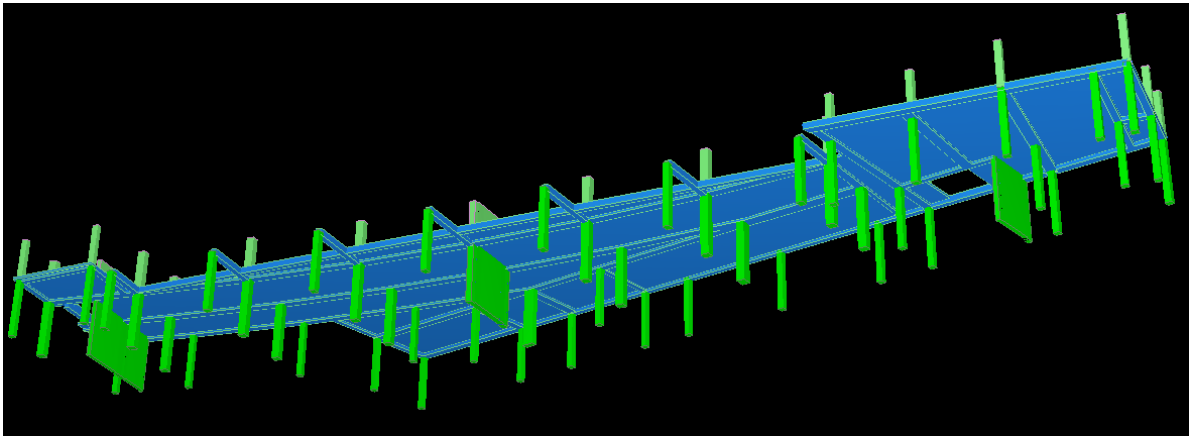

Figure 20

Another area that was redesigned to satisfy deflection and torsion requirements is the south side of the building between gridline 1.9 and gridline 4 on stories three and four. In the two-way flat plate design on story three there was a 12"x26" edge beam and on story four there was no edge beam. However, because the slab thickness was reduced from 12" to 7" deflection and torsion problems were created. Increasing the size of the third story beam to 18"x26" and adding a 18"x18" edge beam on the fourth floor proved to be a viable solution. The location of the added fourth floor edge beam is shown in figure 22 on the previous page in green.

Using RAM Concepts vertical deflection plots as guides, areas of floor slabs with relatively high deflection were inspected and redesigned until they had less than L/360 live load deflection and L/240 long term deflection. When determining the long term deflection a creep factor of 3 was applied to the dead load deflection. No creep factor was applied to the live load which was assumed to not be sustained. Figure 23 below is the vertical deflection plot of the finalized third floor design.

Third Floor Deflection Plan

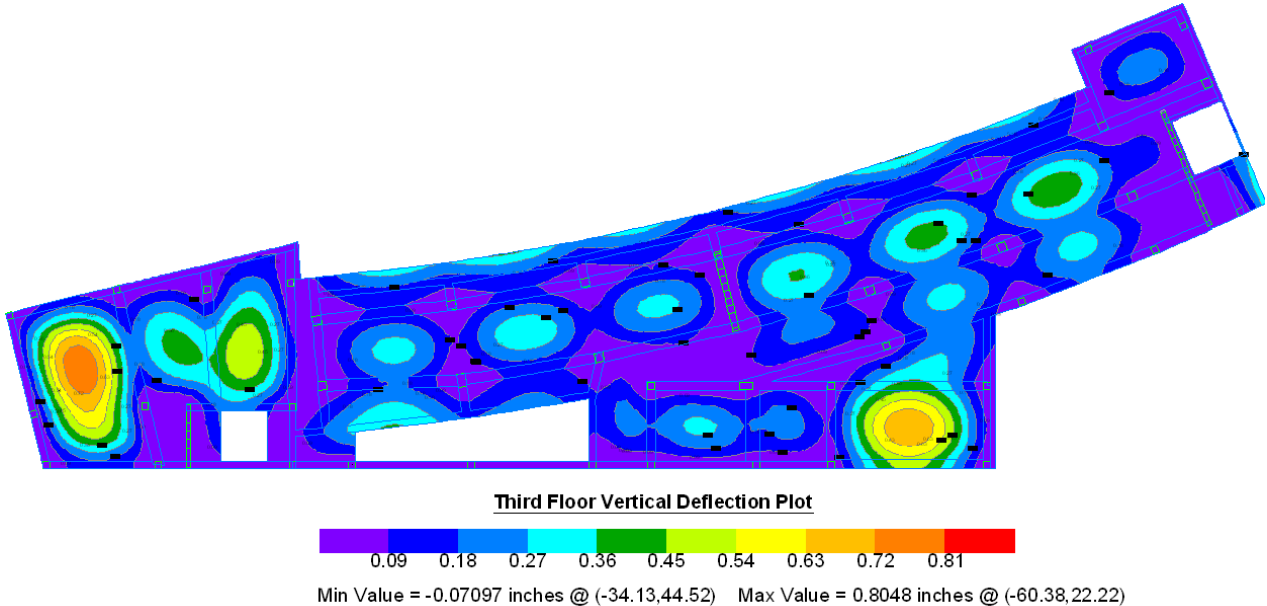

Figure 23

Once all torsional failures and excess deflections in the RAM Concept models were resolved, data from the models was exported to be used in additional design procedures.

To perform column takedowns of the gravity loads throughout the building, the column reactions from the model of each floor were exported to Excel. Reactions were exported for two load cases, Dead+Balanced and Live. In Excel the values from each floor were indexed and combined to obtain the total axial load moment and shear at the base of each column due to gravity loading.

Second Floor Design Check Status Plan All OK

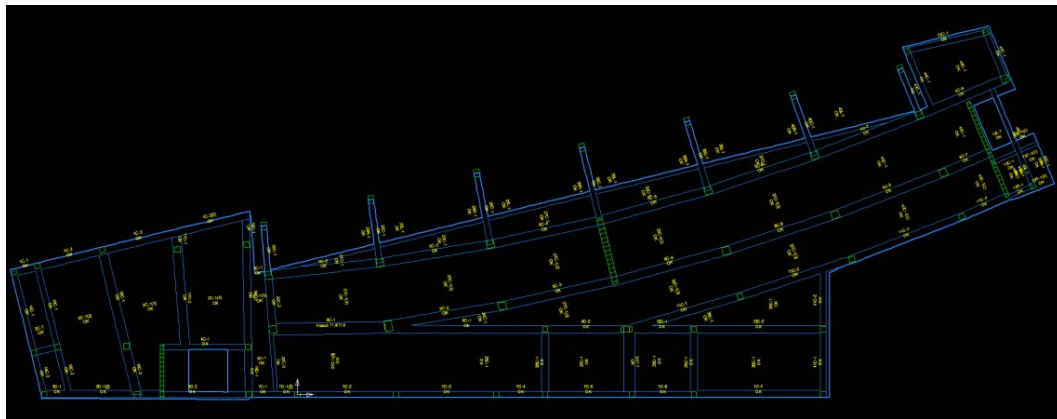

Figure 24

Second Floor Dead+Balanced Load Takedowns

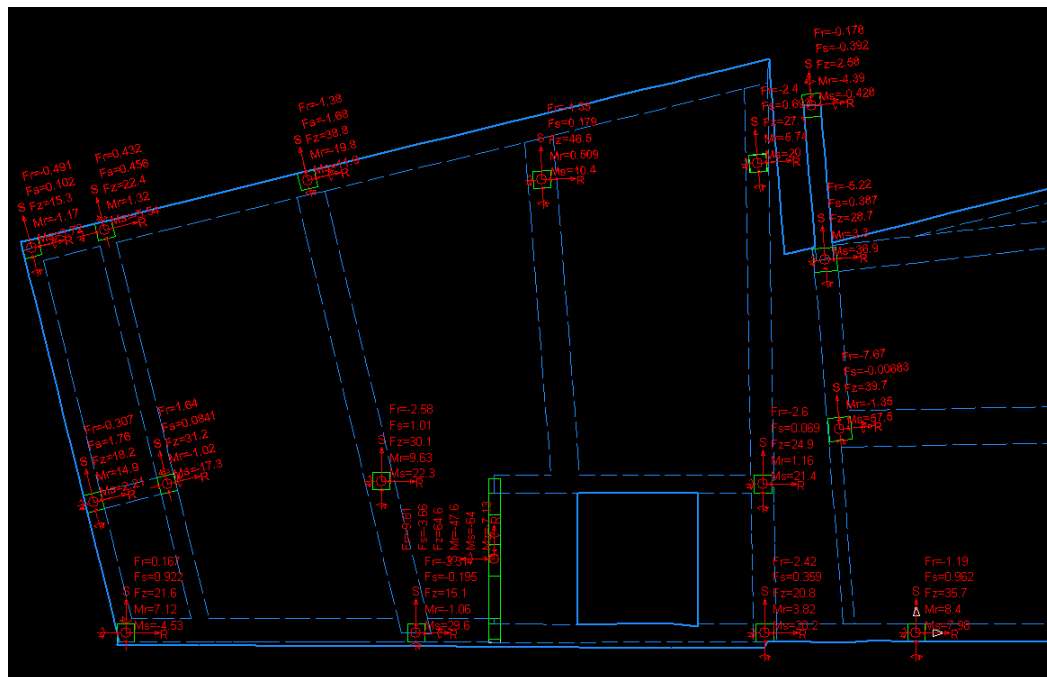

Figure 25

The RAM Concept generated shear and flexural reinforcement plans were exported to AutoCAD to be incorporated in the final gravity system design. The RAM Concept output for flexural reinforcement, in part due to uncontrollable geometries associated with design strips, is disorganized and difficult to read quickly. In contrast to the flexural reinforcement output, the shear reinforcement design output is sufficiently organized to be used without significant modification.

Typical Shear Reinforcement Plan

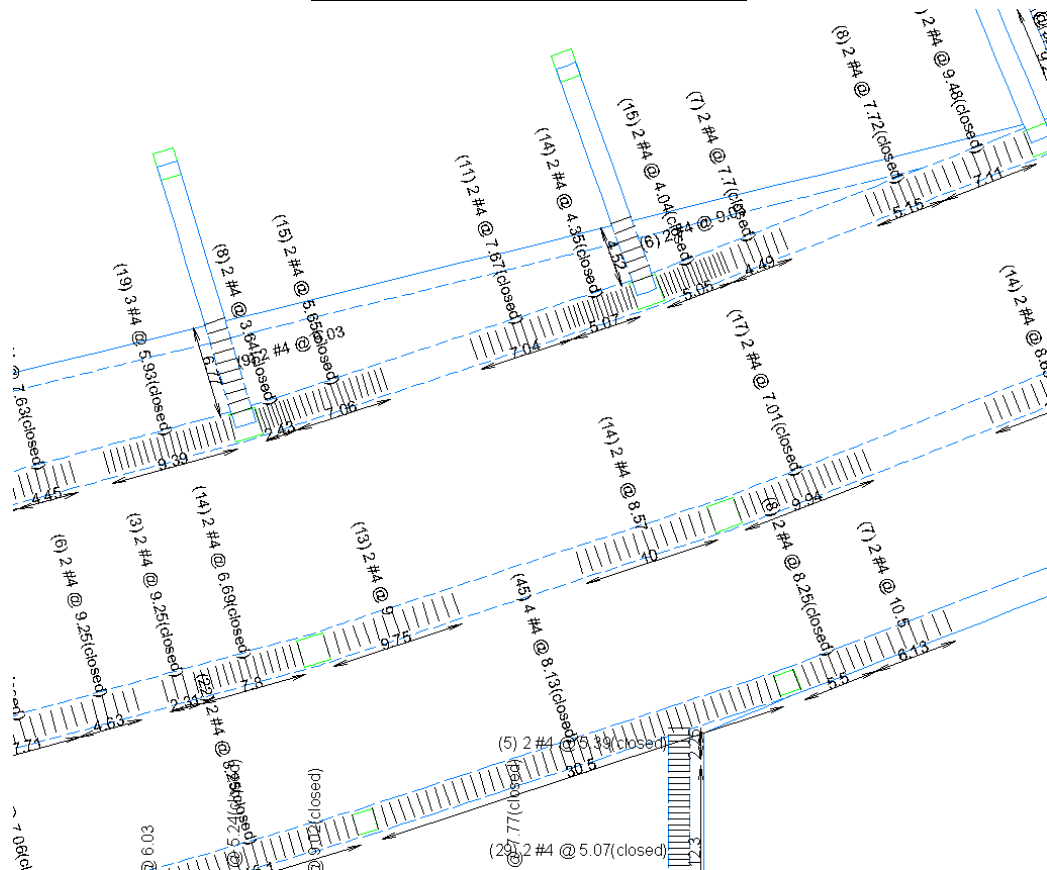

Figure 26

Lateral System Redesign

Wind Loading

| Wind Loading Design Values | |
|--------------------------------|---------|
| Basic Wind Speed | 110MPH |
| Wind Importance Factor | 1.15 |
| Wind Exposure Category | B |
| Gust Response Factor | 0.85 |
| Internal pressure Coefficients | +/-0.18 |

Figure 27

Using the wind loading design values above, the wind pressures to be applied to the Game Day Building were determined in accordance with ASCE 7-05 section 6.5. method 2 the analytical procedure. The windward and leeward pressures determined are shown in the figure below. The 374 plf and 226 plf values represent the calculated wind pressure applied to the roof diaphragm per linear foot of the two parapet heights.

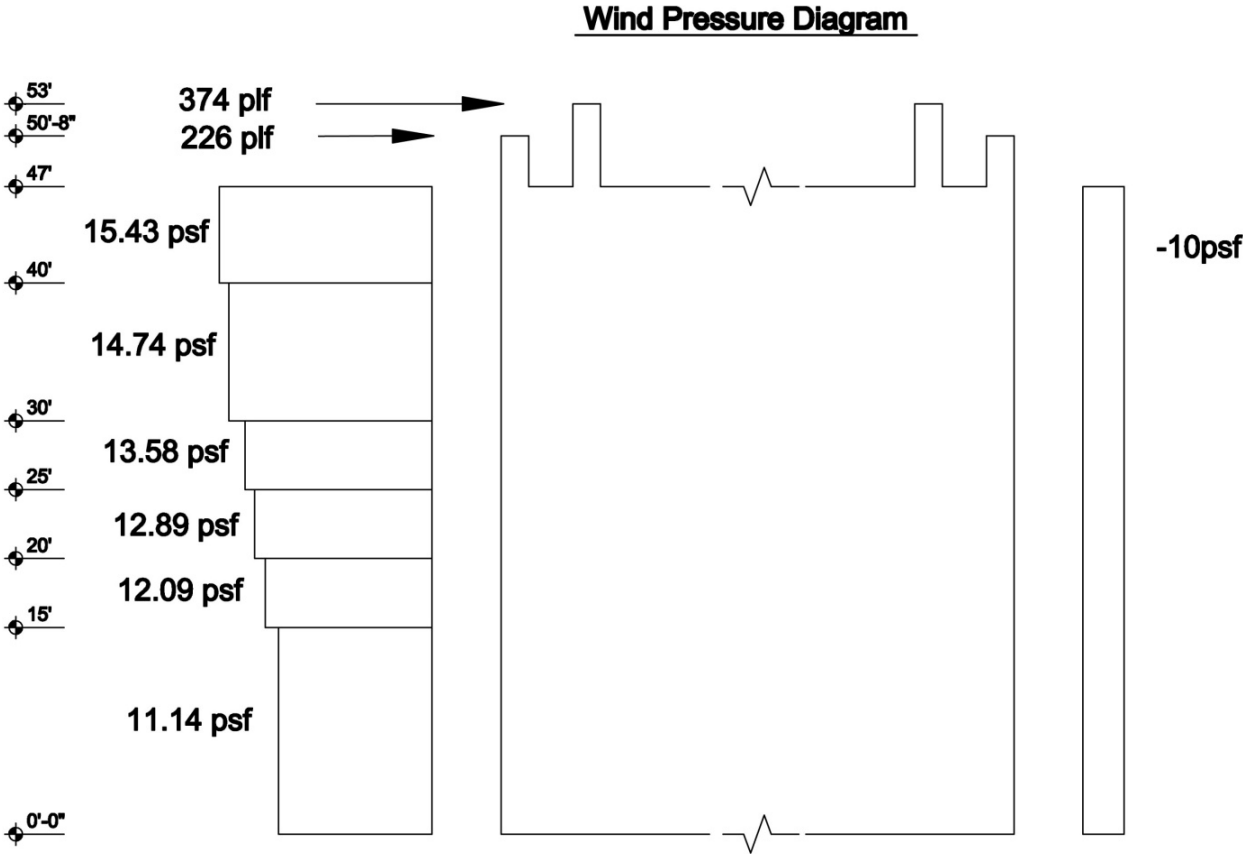

Figure 28

The Game Day Building’s exterior facade does not consistently follow the perimeter of the floor slabs, especially on the first and second floors. To determine overall story forces due to wind loading an approximate model of the Game Day Building’s facade’s geometry was made in AutoCAD. The design wind pressures were then applied to the models geometry. The wind loading story forces were then determined by summing the wind pressure imposed on the facade assuming each floor diaphragm’s tributary height extended halfway to the floors above and below. The uplift effects of wind on the roof slab and the non enclosed areas of floor slabs were then studied. Through quick hand calculations it was determined that a conservatively high value of the effective uplift force was five psf. Five psf being far lower than the self weight of the slabs, it was determined that uplift wind loading was negligible. Therefore, uplift wind loading was not included in any structural analysis.

Approximate Game Day Building Facade Geometry

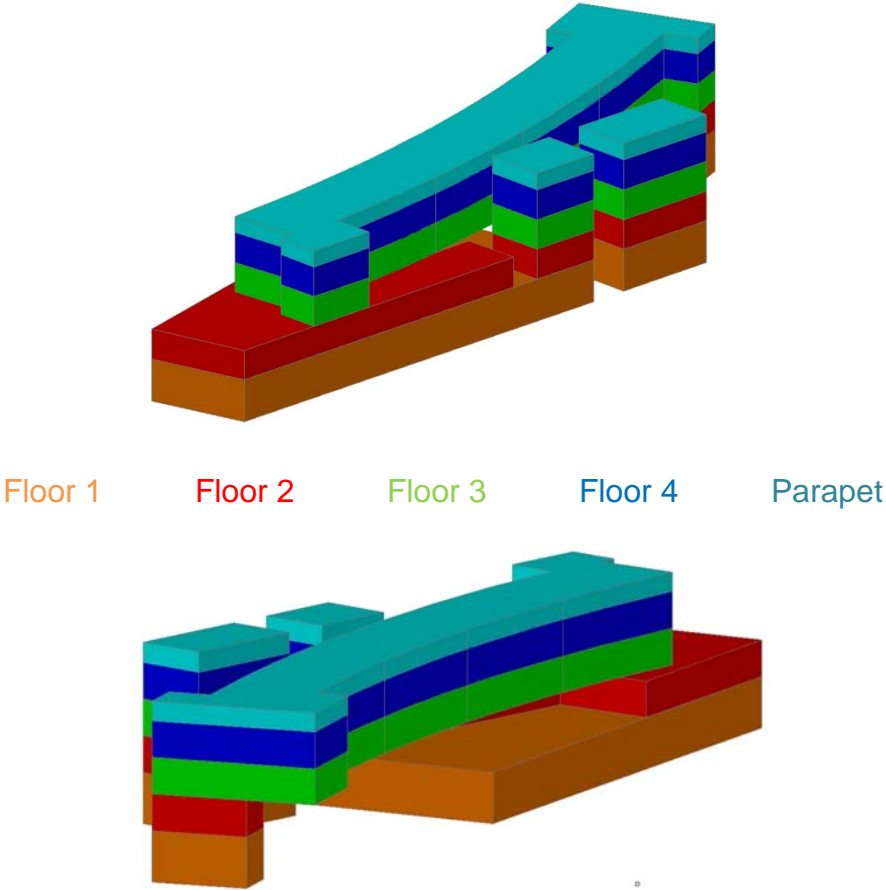

Figure 29

Seismic Loading

The seismic loading for the Game Day Building was determined in accordance with the equivalent lateral force procedure in ASCE 7-05. The mass of each story was assumed to be uniformly distributed over the slab extents of each story. Therefore, each diaphragms center of mass was assumed to be at its geometric centroid. In the analysis of the existing structure this was a very accurate assumption because the majority of the mass of the building was located in a slab of uniform thickness. In the redesigned floor system this simplifying assumption is slightly less accurate due to varying slab depth but still permissible. Figure 31 shows the determination of the seismic mass per area applied to the diaphragms and the equivalent uniform slab thickness it represents.

| Seismic Design Values | |
|------------------------------|--------|
| Site Class | D |
| Importance Factor, I | 1.25 |
| S_s | 0.118 |
| S_1 | 0.048 |
| F_a | 1.6 |
| F_v | 2.4 |
| $S_{DS} = (2/3) * F_a * S_s$ | 0.126 |
| $S_{D1} = (2/3) * F_v * S_1$ | 0.0768 |
| Seismic Design Category | B |
| Building Height, h | 47' |
| C_t | 0.02 |
| x | 0.75 |
| $T_a = C_t * h^x$ | 0.359 |
| C_u | 1.7 |
| $C_u T_a$ | 0.61 |
| T_L | 8 |

Figure 30

| Seismic Weight Determination | | | | | | | | | | | | | |
|------------------------------|------------------------------|-----------------|-----------------------|-----------------------|---------------------------------|-----------------------|------------------|----------------------|-----------------|-----------------------------|------------------------|--------------------------------------|-----------------------|
| Floor | Volume Conc. in Beams & Slab | | Density of Concrete | Weight of Beam & Slab | Vertical Surface Area of Facade | Avg. Weight of Facade | Weight of Facade | Total Seismic Weight | Diaphragm Area | Acceleration due to Gravity | Total Mass | Mass/Area | Equivalent Slab Depth |
| Units | yd ³ | ft ³ | lb/(ft ³) | kips | ft ² | psf | kips | kips | in ² | in/sec ² | k-sec ² /in | sec ² /in/in ² | in |
| Roof | 225 | 6080 | 150 | 912 | 7846 | 30 | 235 | 1147 | 1276626 | 386 | 2.969 | 2.326E-06 | 10.35 |
| Level 4 | 291 | 7860 | 150 | 1179 | 10105 | 30 | 303 | 1482 | 1580776 | 386 | 3.835 | 2.426E-06 | 10.80 |
| Level 3 | 367 | 9917 | 150 | 1488 | 8785 | 40 | 351 | 1839 | 1927576 | 386 | 4.758 | 2.469E-06 | 10.99 |
| Level 2 | 434 | 11710 | 150 | 1756 | 9192 | 40 | 368 | 2124 | 2351198 | 386 | 5.496 | 2.338E-06 | 10.41 |

Figure 31

Overall the new floor system design resulted in 36% reduction in seismic masses compared to the original two-way flat plate system.

Figure 32 shows the design coefficients for seismic force resisting systems under consideration for use in the Game Day Building.

| Design Coefficients for Seismic Force Resisting Systems | | |
|-----------------------------------------------------------------------------------------|--------------------------------------|----------------------------------------|
| Seismic Force Resisting System | Response Modification Coefficient, R | Deflection Amplification Factor, C_d |
| Ordinary Reinforced Concrete Moment Frames | 3 | 2.5 |
| Ordinary Reinforced Concrete Shear Walls | 5 | 4.5 |
| Ordinary Reinforced Concrete Moment Frames and Ordinary Reinforced Concrete Shear Walls | 4.5 | 4 |

Figure 32

Overall Lateral System Design

A 3D ETABS model of the Game Day building was created which included all seven shear walls, all columns, and all beams spanning directly between two columns. Members such as edge beams supported by other beams, not columns, were not modeled because it was assumed that their contribution to the Game Day Building's inherent ordinary concrete moment frames was negligible.

ETABS MODEL 3D VIEW

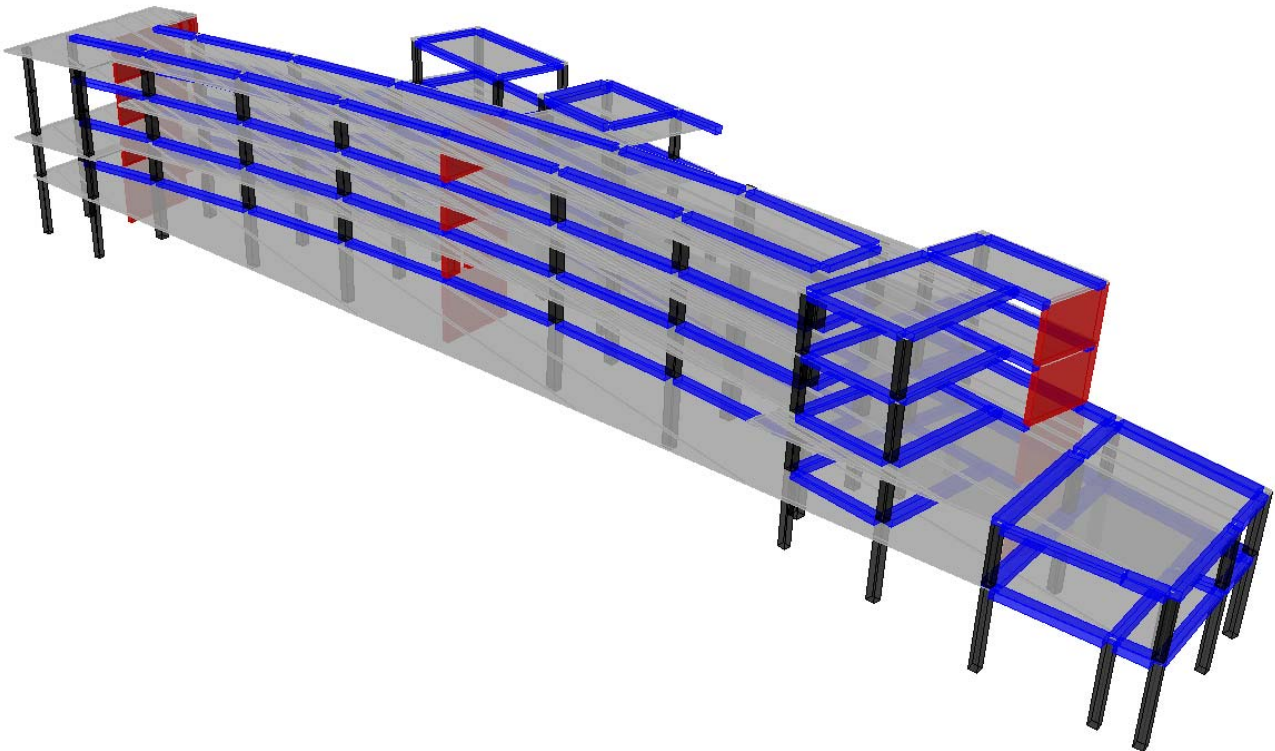

Figure 33

Load cases, for wind story forces were created for all eight variations of the ASCE7-05 prescribed loading situations.

The Game Day Building’s seismic design category is B. The code minimum for application of seismic forces on category B structures is 100% of the seismic loading in two orthogonal directions independently. Six seismic load cases were created, one for each orthogonal direction and an additional two for each direction + and – an accident torsional eccentricity of 5% of the buildings width in that direction. Seismic loads were input through the ETABS IBC 2006 Seismic Loading Interface as seen in figure 35.

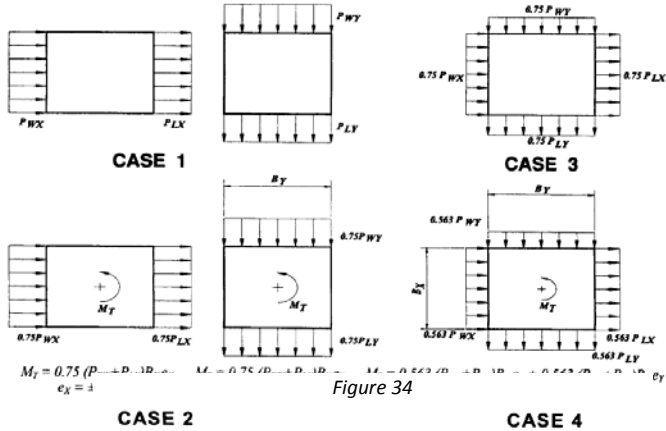

Figure 35

Lateral stiffness modification factors were determined for both seismic and wind load cases in accordance with ACI 318-08 sections 8.8.1 and 10.10.4.1. To take into account the effect of the slab on the stiffness, the stiffness of the beams was increased by a factor of 1.5. The commentary in section 10.10.4 permits one to approximate the moment of inertia of a T beam as 2x the gross moment of inertia. Because theoretically under pure lateral loading one side of the member will be in tension at the top and thus assumed cracked, only half of this permitted additional capacity was considered. To ensure consistency and ease of input the lateral stiffness modification factors were input as multipliers to E_c of the different member types instead of to the moment of inertias of the different member sections. Figure 36 show the effective lateral stiffnesses that were used respectively in ETABS models of the Game Day Building subjected to seismic and wind loading.

| Lateral Stiffness Modification Factors ACI 318-08 Sections 8.8.1 & 10.10.4.1 | |
|---------------------------------------------------------------------------------|--------------------------------------------------|
| E_c (ksi) | $57 \cdot \text{SQRT}(6000) = 4415$ ksi |
| Seismic Loading | |
| $E_{c\text{Beam}}$ | $1.5 \cdot .35 \cdot E_c = 2318$ ksi |
| $E_{c\text{Column/Wall}}$ | $0.7 \cdot E_c = 3091$ ksi |
| $E_{c\text{Cracked Wall}}$ | $0.35 \cdot E_c = 1545$ ksi |
| Wind Loading | |
| $E_{c\text{Beam}}$ | $1.4 \cdot 1.5 \cdot .35 \cdot E_c = 3245.2$ ksi |
| $E_{c\text{Column/Wall}}$ | $1.4 \cdot 0.7 \cdot E_c = 4327.4$ ksi |
| $E_{c\text{Cracked Wall}}$ | $1.4 \cdot 0.35 \cdot E_c = 2163$ ksi |

Figure 36

Analyzing the models with all the shear walls and moment frames in place the period and deflections were extremely small. Because most of the beams designed for the gravity were in the East and West plan direction it was decided to remove the four shear walls in that direction. Figures 37 ,38 and 39 depict the lateral system modifications.

The plan in figure 40 summaries the redesigned lateral system of the Game Day Building in both the North/South and East/West Plan directions. In order to help both cantilevered slab deflection on the upper floors, increase lateral stiffness, and ensure strong column weak beam failure mechanisms the columns cross sections along gridlines B and C were increased from 18"x18" to 24"x24".

Shear Wall Number 7 Removal Detail

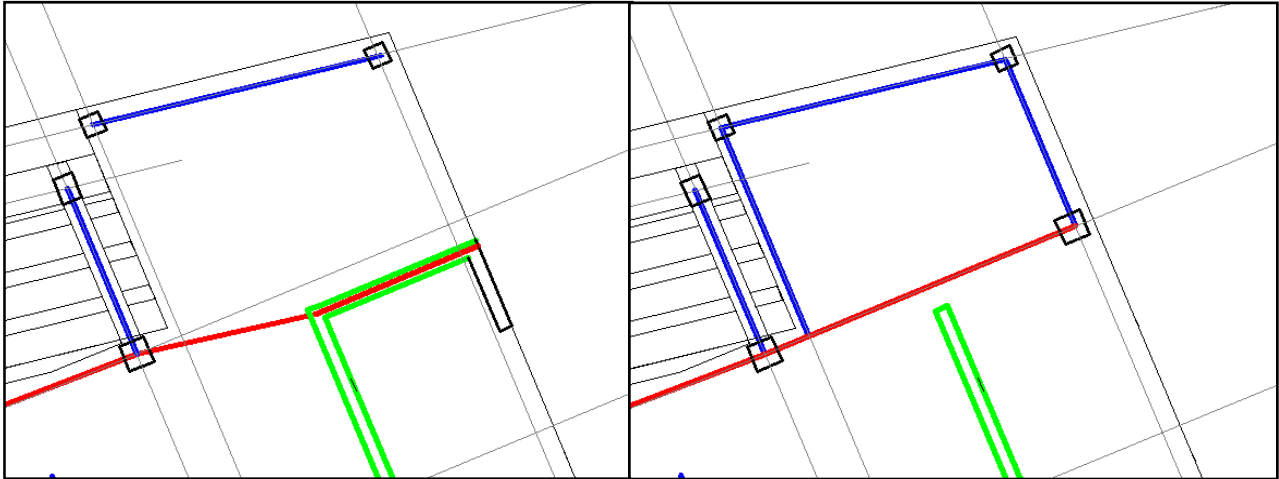

Figure 37

Shear Walls Number 1 and 3 Removal Detail

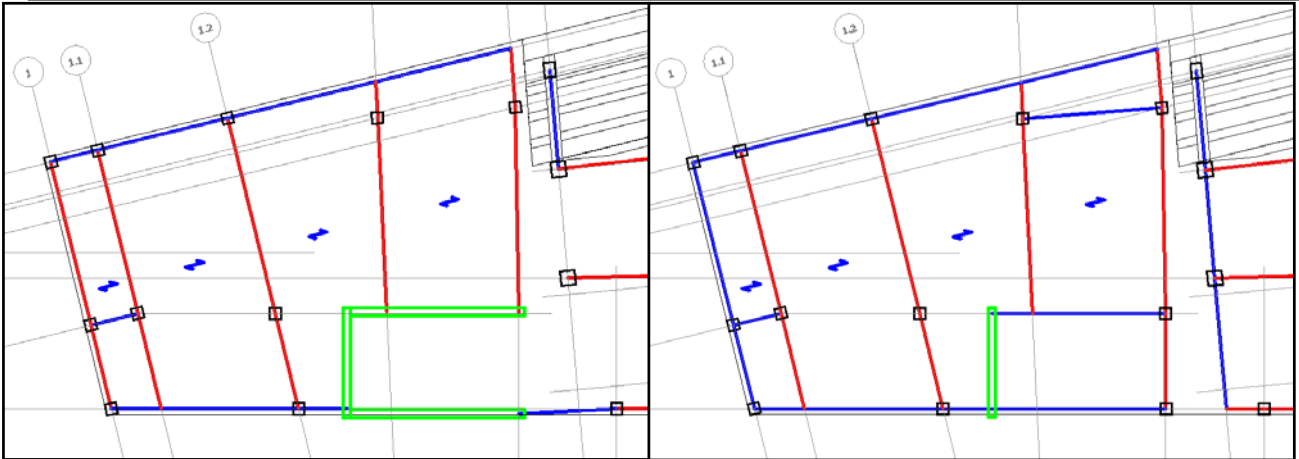
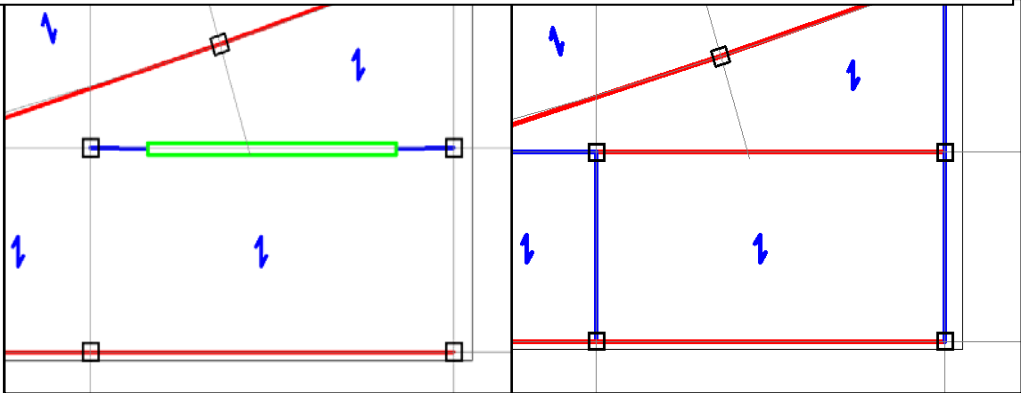

Figure 38



Shear Wall Number 5 Removal Detail



- = Post Tensioned Concrete Beam
- = Reinforced Concrete Beam
- = Support Column or Wall

Figure 39

Lateral System Summary Plan

-  = Columns Sections Increased
-  = Plan East/West Direction Lateral System Components
-  = Plan North/South Direction Lateral System Components

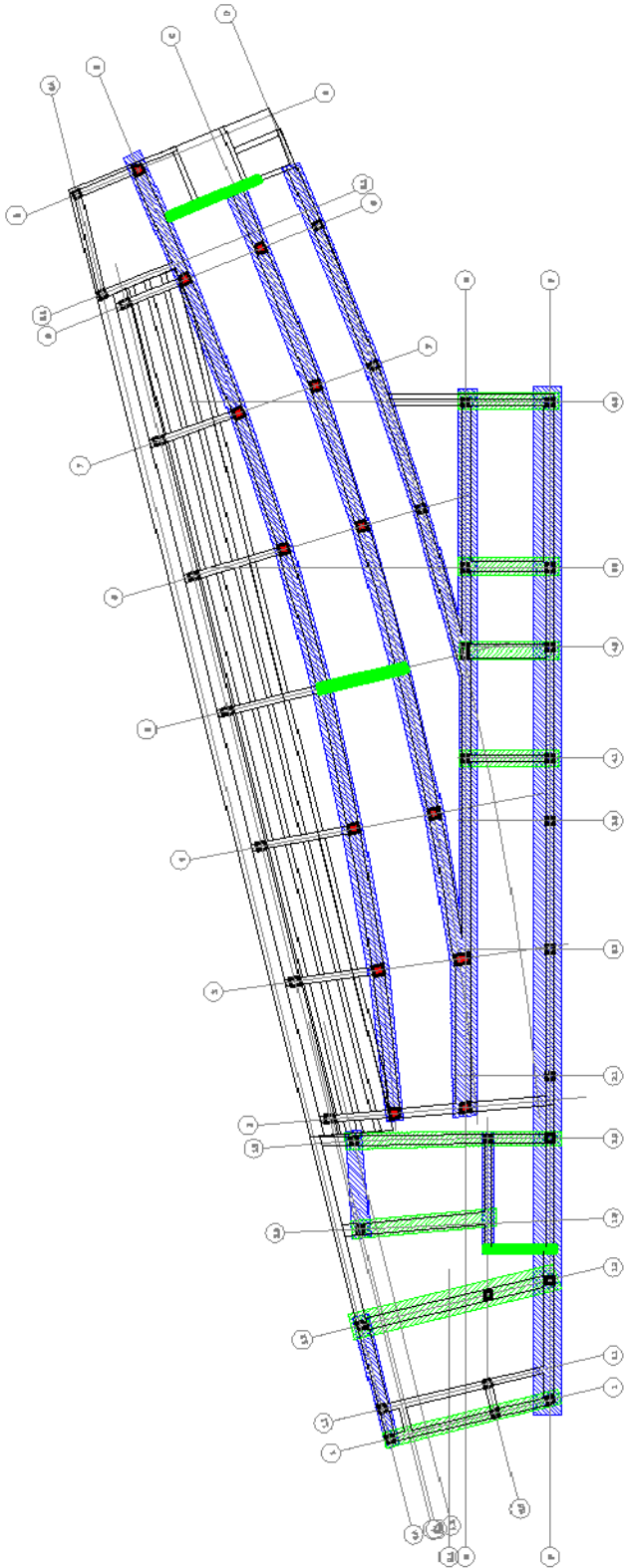

Figure 40

Lateral System Performance under Wind Loading

Due to the inclusion of the moment frames the R factor for the North/South direction of the building decreased from 5 to 4.5 increasing the seismic force magnitude by 11%. Due to the removal of all the shear walls oriented in the East/West direction the lateral force resisting system for that axis was reclassified as ordinary reinforced concrete moment frames. This change in classification decreased the R factor to 3 resulting in a 67% increase in the magnitude of seismic forces in that direction. The 36% reduction in seismic mass associated with the redesign of the gravity system helped to offset these increases.

In the redesigned lateral system the critical load case in North/South direction remained the wind load coming from the north or south. The consideration of the stiffness of the moment frames in the North/South direction more than made up for the loss in shear wall stiffness due to the removal of the coupled shear walls that acted as flanges in the original design.

Deflection Caused by Wind from the South

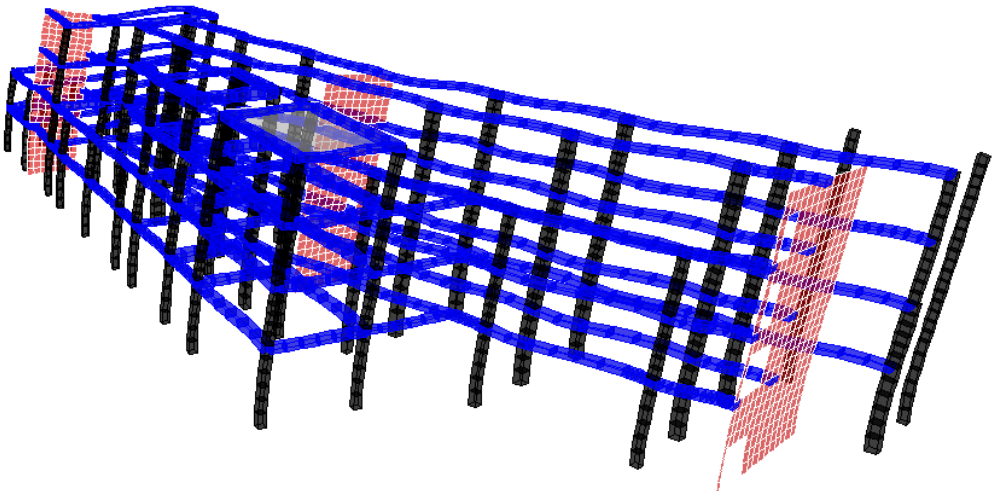

Figure 41

| Max Deflections Caused By Wind Loading | | | | |
|-----------------------------------------------|-----------------------------------|-----------------------------------|------------------------|----------------------------------------|
| Story | Max Deflection X (in.) | Max Deflection Y (in.) | h/600 (in.) | Deflection Check (OK or NG) |
| Roof | 0.0686 | 0.0868 | 0.2133 | OK |
| Floor 4 | 0.0709 | 0.0401 | 0.2133 | OK |
| Floor 3 | 0.0707 | 0.0376 | 0.2133 | OK |
| Floor 2 | 0.0684 | 0.0340 | 0.3000 | OK |

Figure 42

Lateral System Performance under Seismic Loading

Due to the decrease in R factor the seismic loads were critical in the East/West direction. The removals of the shear walls considerably increased the flexibility of the building. However, the combination of the stiffness of the original design exceeding the code required limits significantly and Cd being reduced from 4.5 to 2.5 because of the change of lateral system classification the maximum calculated seismic drift ratios of the Game Day Building with the redesigned lateral system were still well below the code required limit.

Deflection Caused by Seismic Loading to the East

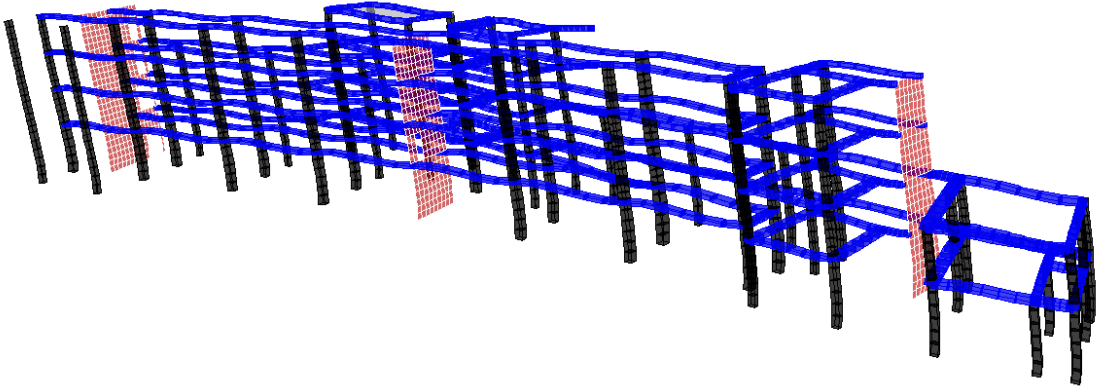

Figure 43

| Seismic Drift Analysis | | | | | | |
|------------------------|-----|-----------------------------|-------------------------|---------------------|----------------------|------------------------|
| East/West Direction | | | | | | |
| Story | Cd | Average Diaphragm Drift | Max Diaphragm Drift | Seismic Drift Limit | Drift Limit Exceeded | Torsional Irregularity |
| Roof | 2.5 | 0.002915 | 0.002953 | 0.02 | No | No |
| Floor 4 | 2.5 | 0.003378 | 0.003418 | 0.02 | No | No |
| Floor 3 | 2.5 | 0.003383 | 0.003418 | 0.02 | No | No |
| Floor 2 | 2.5 | 0.002220 | 0.002245 | 0.02 | No | No |
| North South Direction | | | | | | |
| Story | Cd | Average Diaphragm Drift (Y) | Max Diaphragm Drift (Y) | Seismic Drift Limit | Drift Limit Exceeded | Torsional Irregularity |
| Roof | 4 | 0.001120 | 0.001204 | 0.02 | No | No |
| Floor 4 | 4 | 0.000816 | 0.000960 | 0.02 | No | No |
| Floor 3 | 4 | 0.000816 | 0.000884 | 0.02 | No | No |
| Floor 2 | 4 | 0.000396 | 0.000472 | 0.02 | No | No |

Figure 44

After the overall lateral systems performance was determined to be acceptable under both wind and lateral loads strength capacity checks of the beams, columns, and shear walls, participating in the lateral system were performed.

Beam Design for Lateral Loading

In order to design the beams for the combination of gravity and lateral loads the member forces resulting from all of the unfactored wind and seismic load cases determined by the ETABS model were exported into excel. By inspection the lateral loads of the largest magnitudes were on the second floor. In Excel the ETABS output was sorted and indexed to determine the maximum wind and seismic moment and shear each beam was subjected to. Once determined the unfactored wind and seismic design moments and shears for all of the post tensioned beams on the second floor were copied into the Excel file used to design them by hand calculation methods. The additional ASCE-7-05 load combos which include lateral loads were then considered in addition to the gravity loads already being designed to determine the Mu+, Mu-, and Vu for each beam under combined gravity and lateral loading.

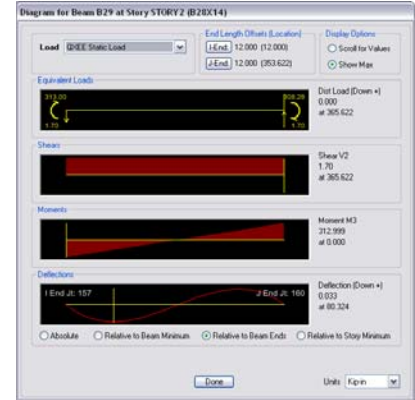

Figure 45

| PT Moment Frame Critical Beam Loading Analysis | | | | | | | | | | | | | | | | | | | | | | | |
|------------------------------------------------|-------------------|----------------------|--------------------------------|----------|---------|-------------|----------|---------|-----------|----------|---------|----------|----------|---------|-----------|----------|---------|----------------|--------|-----------------------|--------------------------|--|--|
| Beam Location | Lateral Loads | | LRFD Load Combo Factored Loads | | | | | | | | | | | | | | | Design Moments | | Controlling Load Case | % Diff From Gravity Load | | |
| | M _{wind} | M _{seismic} | 1.2D+1.6L | | | 1.2D+1.6W+L | | | 0.9D+1.6W | | | 1.2D+E+L | | | 0.9D+1.0E | | | Mu+ | Mu- | | | | |
| | k-ft | k-ft | Col (A) | Mid Span | Col (B) | Col (A) | Mid Span | Col (B) | Col (A) | Mid Span | Col (B) | Col (A) | Mid Span | Col (B) | Col (A) | Mid Span | Col (B) | k-ft | k-ft | | | | |
| B-2-3 | 14.7 | 20.7 | -150.4 | 154.3 | -203.0 | -131.8 | 131.0 | -179.8 | 12.4 | 77.6 | -25.1 | -128.8 | 131.0 | -176.8 | 9.4 | 77.6 | -28.1 | 154.3 | -203.0 | 1.2D+1.6L | 0.00% | | |
| B-3-4 | 14.5 | 20.0 | -213.0 | 149.3 | -214.6 | -186.5 | 124.3 | -187.7 | -26.5 | 67.2 | -26.6 | -183.4 | 124.3 | -184.5 | -29.7 | 67.2 | -29.8 | 149.3 | -214.6 | 1.2D+1.6L | 0.00% | | |
| B-4-5 | 14.9 | 21.4 | -216.8 | 159.7 | -217.4 | -188.9 | 133.7 | -189.3 | -22.8 | 74.3 | -22.8 | -186.4 | 133.7 | -188.8 | -25.2 | 74.3 | -25.3 | 159.7 | -217.4 | 1.2D+1.6L | 0.00% | | |
| B-5-6 | 16.2 | 21.0 | -217.4 | 159.7 | -216.9 | -191.3 | 133.7 | -190.9 | -20.7 | 74.3 | -20.7 | -186.5 | 133.7 | -186.1 | -25.6 | 74.3 | -25.6 | 159.7 | -217.4 | 1.2D+1.6L | 0.00% | | |
| B-6-7 | 14.8 | 19.9 | -214.8 | 149.4 | -212.6 | -188.3 | 124.4 | -186.8 | -26.1 | 67.2 | -26.0 | -184.6 | 124.4 | -183.0 | -29.9 | 67.2 | -29.8 | 149.4 | -214.8 | 1.2D+1.6L | 0.00% | | |
| B-7-8 | 14.9 | 19.9 | -195.9 | 133.6 | -198.8 | -174.7 | 111.3 | -176.7 | -23.6 | 60.1 | -23.7 | -170.8 | 111.3 | -172.8 | -27.5 | 60.1 | -27.7 | 133.6 | -198.8 | 1.2D+1.6L | 0.00% | | |
| B-8-9 | 16.3 | 21.3 | -244.4 | 169.9 | -80.6 | -212.1 | 139.9 | -85.2 | -27.7 | 72.0 | 15.5 | -207.3 | 139.9 | -80.5 | -32.5 | 72.0 | 10.8 | 169.9 | -244.4 | 1.2D+1.6L | 0.00% | | |
| C-2-3 | 17.8 | 25.7 | -261.9 | 233.5 | -361.3 | -220.7 | 193.7 | -314.3 | -4.2 | 102.8 | -84.6 | -217.9 | 193.7 | -311.5 | -7.0 | 102.8 | -87.4 | 233.5 | -361.3 | 1.2D+1.6L | 0.00% | | |
| C-3-4 | 15.9 | 22.4 | -198.7 | 137.8 | -191.6 | -177.4 | 115.8 | -172.2 | -18.5 | 65.1 | -18.0 | -174.2 | 115.8 | -169.1 | -21.7 | 65.1 | -21.2 | 137.8 | -198.7 | 1.2D+1.6L | 0.00% | | |
| C-4-5 | 18.1 | 24.0 | -228.9 | 159.4 | -235.2 | -204.7 | 132.5 | -209.3 | -25.7 | 70.9 | -26.4 | -199.8 | 132.5 | -204.4 | -30.6 | 70.9 | -31.3 | 159.4 | -235.2 | 1.2D+1.6L | 0.00% | | |
| C-5-6 | 16.9 | 24.3 | -271.9 | 189.7 | -275.0 | -235.1 | 157.3 | -237.4 | -35.7 | 83.7 | -36.1 | -232.3 | 157.3 | -234.6 | -38.5 | 83.7 | -38.9 | 189.7 | -275.0 | 1.2D+1.6L | 0.00% | | |
| C-6-7 | 16.6 | 22.5 | -273.9 | 189.1 | -274.3 | -236.0 | 156.9 | -236.2 | -36.5 | 83.7 | -36.6 | -232.0 | 156.9 | -232.3 | -40.5 | 83.7 | -40.5 | 189.1 | -274.3 | 1.2D+1.6L | 0.00% | | |
| C-7-8 | 16.4 | 22.2 | -279.0 | 191.9 | -263.7 | -239.4 | 158.9 | -228.3 | -37.3 | 84.0 | -35.7 | -235.3 | 158.9 | -224.3 | -41.3 | 84.0 | -39.8 | 191.9 | -279.0 | 1.2D+1.6L | 0.00% | | |
| C-8-9 | 36.1 | 47.8 | -121.8 | -9.2 | -43.1 | -161.9 | -12.7 | -94.9 | -6.0 | -20.4 | 34.4 | -151.9 | -12.7 | -84.9 | -16.0 | -20.4 | 24.4 | 34.4 | -161.9 | 1.2D+1.6W+L | 32.93% | | |
| E-3-4.1 | 36.1 | 47.8 | -328.7 | 240.5 | -303.7 | -308.8 | 201.6 | -290.8 | -14.0 | 111.8 | -12.2 | -298.8 | 201.6 | -280.8 | -24.0 | 111.8 | -22.2 | 240.5 | -328.7 | 1.2D+1.6L | 0.00% | | |
| E-4.1-5 | 18.0 | 20.0 | -179.3 | 24.1 | -168.5 | -174.1 | 15.8 | -166.5 | -38.8 | -3.3 | -38.3 | -165.3 | 15.8 | -157.7 | -47.6 | -3.3 | -47.1 | 24.1 | -179.3 | 1.2D+1.6L | 0.00% | | |
| D-5-6 | 12.5 | 17.2 | -188.3 | 160.0 | -202.3 | -161.9 | 135.3 | -171.6 | -15.8 | 78.7 | -15.8 | -159.1 | 135.3 | -168.9 | -18.5 | 78.7 | -18.5 | 160.0 | -202.3 | 1.2D+1.6L | 0.00% | | |
| D-6-7 | 12.6 | 17.3 | -235.3 | 184.7 | -231.8 | -198.2 | 154.3 | -195.7 | -27.6 | 85.1 | -27.4 | -195.4 | 154.3 | -192.8 | -30.4 | 85.1 | -30.2 | 184.7 | -235.3 | 1.2D+1.6L | 0.00% | | |
| D-7-8 | 12.5 | 17.1 | -194.7 | 97.1 | -132.6 | -176.3 | 79.6 | -121.4 | -47.1 | 39.0 | -8.8 | -173.4 | 79.6 | -118.5 | -50.0 | 39.0 | -11.7 | 97.1 | -194.7 | 1.2D+1.6L | 0.00% | | |
| D-8-8.5 | 24.1 | 30.5 | -66.9 | -9.2 | -33.3 | -93.6 | -10.5 | -69.9 | 11.3 | -13.4 | 11.9 | -85.5 | -10.5 | -61.9 | 3.2 | -13.4 | 3.8 | 11.9 | -93.6 | 1.2D+1.6W+L | 39.92% | | |
| F-2.1-3.1 | 19.5 | 28.8 | -88.3 | 99.5 | -171.0 | -94.8 | 82.5 | -168.3 | 25.1 | 43.2 | -27.4 | -92.3 | 82.5 | -165.9 | 22.6 | 43.2 | -29.9 | 99.5 | -171.0 | 1.2D+1.6L | 0.00% | | |
| F-3.1-3.8 | 16.7 | 24.6 | -155.5 | 89.4 | -137.6 | -148.4 | 72.5 | -136.4 | -16.9 | 33.5 | -18.6 | -146.3 | 72.5 | -134.3 | -19.0 | 33.5 | -20.6 | 89.4 | -155.5 | 1.2D+1.6L | 0.00% | | |
| F-3.8-4.1 | 27.7 | 40.8 | -95.6 | -42.2 | -87.2 | -128.2 | -41.7 | -122.5 | -12.1 | -40.6 | -12.9 | -124.6 | -41.7 | -119.0 | -15.6 | -40.6 | -16.5 | -12.1 | -128.2 | 1.2D+1.6W+L | 33.98% | | |
| F-4.1-4.9 | 17.0 | 25.1 | -107.9 | 65.9 | -108.4 | -113.5 | 52.5 | -113.8 | -9.1 | 21.3 | -8.9 | -111.4 | 52.5 | -111.7 | -11.2 | 21.3 | -11.0 | 65.9 | -107.9 | 1.2D+1.6W+L | 4.99% | | |
| F-4.9-5.6 | 23.6 | 34.7 | -92.3 | -28.3 | -132.1 | -120.3 | -29.5 | -148.1 | -22.2 | -32.3 | -22.3 | -117.3 | -29.5 | -145.0 | -25.3 | -32.3 | -25.4 | -22.2 | -148.1 | 1.2D+1.6W+L | 12.13% | | |
| F-5.6-6.6 | 15.1 | 22.2 | -267.9 | 202.4 | -170.6 | -238.6 | 169.8 | -147.3 | -65.1 | 93.3 | 12.5 | -236.7 | 169.8 | -145.3 | -67.0 | 93.3 | 10.5 | 202.4 | -267.9 | 1.2D+1.6L | 0.00% | | |
| 1.1.F.E.5 | 4.5 | 2.9 | -26.1 | 9.3 | -76.4 | -27.9 | 5.7 | -70.6 | -1.5 | -2.7 | -27.3 | -23.7 | 5.7 | -66.4 | -5.7 | -2.7 | -31.5 | 9.3 | -76.4 | 1.2D+1.6L | 0.00% | | |
| 1.1.E.5-0.A | 3.4 | 3.6 | -114.0 | 99.9 | -82.5 | -91.8 | 84.6 | -62.5 | -18.6 | 49.9 | 5.8 | -90.0 | 84.6 | -60.6 | -20.4 | 49.9 | 4.0 | 99.9 | -114.0 | 1.2D+1.6L | 0.00% | | |
| 1.2.F.E.4 | 8.3 | 5.0 | -27.7 | -15.0 | -138.5 | -39.5 | -16.2 | -127.5 | -9.5 | -19.0 | -45.5 | -31.2 | -16.2 | -119.2 | -17.9 | -19.0 | -53.8 | -9.5 | -138.5 | 1.2D+1.6L | 0.00% | | |
| 1.2.E.4-0.A | 5.0 | 3.9 | -261.7 | 199.7 | -205.0 | -210.5 | 165.0 | -159.2 | -60.4 | 86.5 | -21.5 | -206.3 | 165.0 | -155.1 | -64.6 | 86.5 | -25.7 | 199.7 | -261.7 | 1.2D+1.6L | 0.00% | | |
| 1.8.E.4-A.1 | 6.2 | 3.0 | -169.2 | 211.5 | -282.2 | -134.6 | 174.4 | -226.8 | -14.0 | 90.5 | -59.0 | -127.7 | 174.4 | -219.8 | -21.0 | 90.5 | -65.9 | 211.5 | -282.2 | 1.2D+1.6L | 0.00% | | |
| 1.8.A.1-0.A | 0.0 | 0.0 | -179.5 | -81.8 | -0.3 | -144.7 | -66.0 | -0.2 | -65.9 | -30.4 | 0.0 | -144.7 | -66.0 | -0.2 | -65.9 | -30.4 | 0.0 | 0.0 | -179.5 | 1.2D+1.6L | 0.00% | | |
| 1.9.E.4-A.2 | 4.8 | 2.4 | -117.3 | 154.9 | -203.9 | -94.3 | 128.2 | -164.4 | -8.8 | 67.5 | -41.6 | -89.0 | 128.2 | -159.1 | -14.1 | 67.5 | -46.9 | 154.9 | -203.9 | 1.2D+1.6L | 0.00% | | |
| 1.9.A.2-0.A | 0.0 | 0.0 | -79.0 | -35.9 | -26.7 | -68.0 | -33.9 | -26.7 | -43.1 | -29.4 | -26.6 | -68.0 | -33.9 | -26.7 | -43.1 | -29.4 | -26.6 | -79.0 | -35.9 | 1.2D+1.6L | 0.00% | | |

Figure 46

As can be seen in the Figure above in the majority of members 1.2D+1.6L was the controlling load case. The few member in which 1.2D+1.6W+L was the controlling load case had very short spans and had moment capacity significantly exceeding the Mu. Based on this analysis it was concluded that the designs of the slabs and beam based solely on gravity loading did not need to be revised.

Shear Wall Design

Using the shear wall design function of ETABS the maximum shear, moment, and axial load caused by wind and seism loads were determined for the three remaining shear walls. Sorting and indexing the RAM Concept model reaction plan output in Excel determined the shear moment and axial loading due to dead and live loads on each shear wall. Figure 47 shows the results of the load determination. Using determined the ultimate load combinations the shear walls were designed in accordance with ACI-318-08. Excel was used to calculate the shear and capacity and PCA column was used to create an interaction diagram for combined bending and axial loading. Figure 48 on the following page shows the design analysis of Shear Wall 4. All three shear walls were found have adequately capacity using the same reinforcement design specified in the original lateral system design.

| SHEAR WALL LOADING | | | | | |
|--------------------------------|-----------|--------------------------|--------------------------|------------------------------|---------------------------------|
| Shear Wall | Load Case | P _U (Kips) | V _U (Kips) | M _{U Top} (K-ft) | M _{U Bottom} (K-ft) |
| Seismic Loading | | | | | |
| SW2 | QYEE | 13 | 62 | 876 | 1810 |
| SW4 | QYEE | 0 | 106 | 1681 | -3267 |
| SW6 | QYE | 6 | 67 | 1254 | 2264 |
| Wind Loading | | | | | |
| SW2 | W3 | 16 | 95 | 1266 | 2694 |
| SW4 | W1 | 0 | 158 | 2566 | -4937 |
| SW6 | W8 | -2 | 77 | 1700 | 2851 |
| Dead + Balanced Loading | | | | | |
| SW2 | | 280 | -12 | -55 | 28 |
| SW4 | | 674 | -58 | 147 | -74 |
| SW6 | | 250 | 7 | -99 | 49 |
| Live Loading | | | | | |
| SW2 | | 96 | 2 | 152 | -76 |
| SW4 | | 319 | -9 | 29 | -15 |
| SW6 | | 124 | 12 | 190 | -95 |
| LRFD Ultimate Load | | | | | |
| SW2 | 1.2D | 458 | 140 | 2111 | 4268 |
| SW4 | +1.6W+L | 1127 | 174 | 4310 | -8001 |
| SW6 | | 420 | 143 | 2792 | 4527 |
| SW2 | 1.2D | 444 | 50 | 962 | 1767 |
| SW4 | +1.0E+L | 1128 | 27 | 1887 | -3370 |
| SW6 | | 430 | 87 | 1325 | 2228 |
| SW2 | 0.9D | 278 | 142 | 1976 | 4336 |
| SW4 | +1.6W | 606 | 201 | 4237 | -7965 |
| SW6 | | 222 | 129 | 2631 | 4607 |
| SW2 | 0.9D | 264 | 52 | 826 | 1835 |
| SW4 | +1.0E | 606 | 54 | 1814 | -3333 |
| SW6 | | 231 | 73 | 1165 | 2308 |

Figure 47

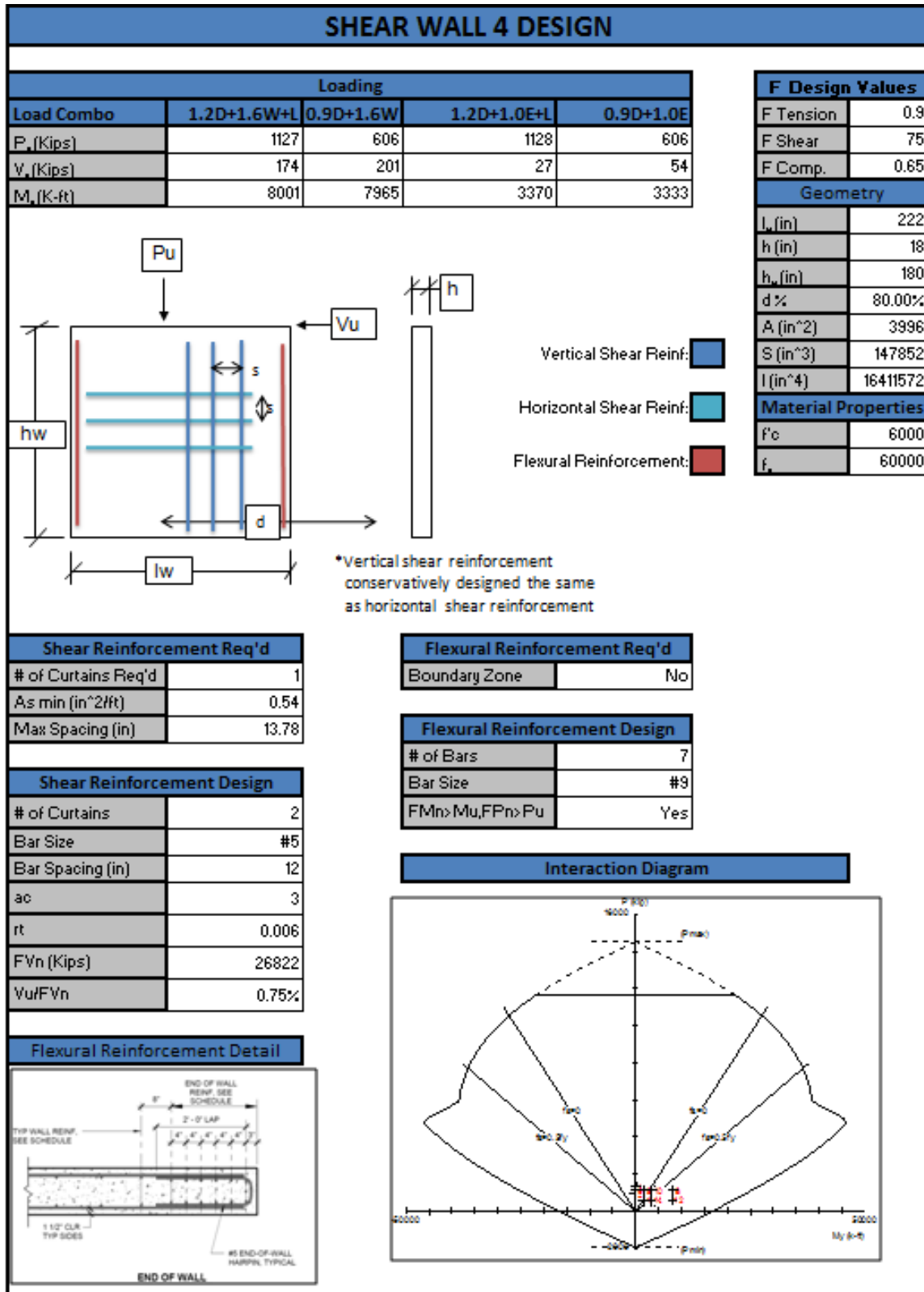

Figure 48

Column Design

The loads to design the columns were compiled from a combination of ETABS and RAM Concept Model Output. Data from the frame element column member force tables in ETABS was exported into Excel for all seismic and wind load cases. Tabulated data from the column below reaction plans, from the RAM Concept models of each floor was exported to the same Excel file for the Dead+Balanced and Live load cases. In Excel the imported data was sorted and indexed to find the Dead+Balanced, Live, Wind, and Seismic moments, shears and axial forces at the base of every column in the building. Then, factored design loads were determined for each column using the ASCE-7 LRFD load combinations. The most severely loaded column of each cross section was analyzed using PCA Column. Figure 49 below is the PCA column analysis of the most severely loaded 18"x18" column in the building.

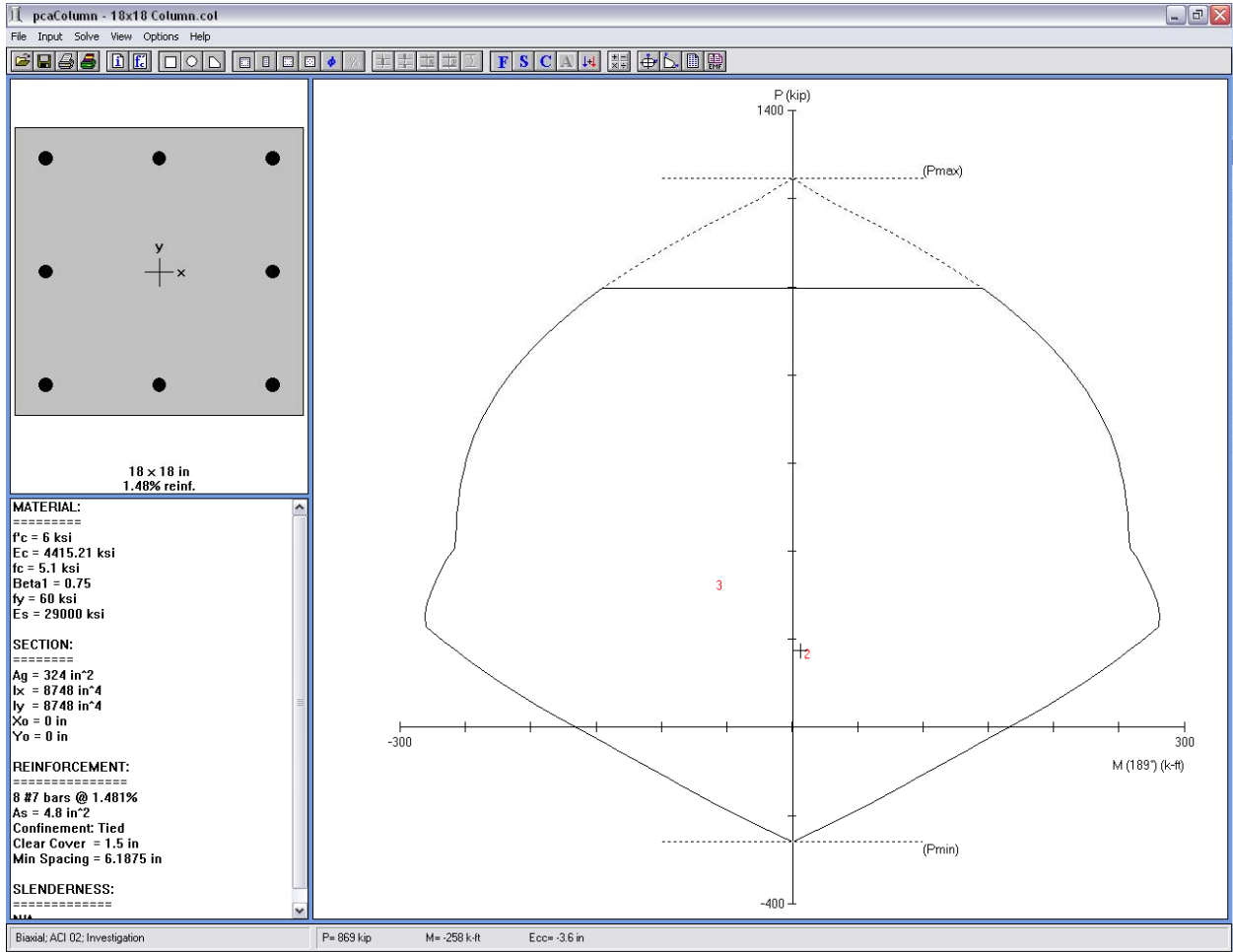

Figure 49

Foundation Redesign

Due to the low bearing capacity of the soil on site the Game Day Building required a deep foundation system. The system selected was square precast prestressed concrete piles driven to a depth of 100' below grade. In the original design a total of 183 piles, located primarily in clusters of 4 below columns and clusters between 8 and 18 below the shear walls, were used. Based on the unfactored loads determined at the base of each column and shear walls in the lateral system analysis the foundation design loads were determined using the ASCE-7-05 ASD load combinations. The 2006 IBC dictates that in order to maintain stability primary structural columns must be supported by a cluster of at least three piles unless the pile cap is laterally braced by a grade beam.

The capacity of an individual pile to resist compression, tension and shear loading is shown in figure 50. Not enough information is available to determine the additional capacity gained through the soil consolidation effects of clustering individual piles.

| Pile Capacities | |
|------------------------------|-----|
| Compression (K/Pile) | 170 |
| Tension (K/Pile) | 80 |
| Shear (K/Pile) ^{*1} | 10 |

Figure 50

With the goal of reducing the number of piles required to support the structure, all of the columns were analyzed to determine if they could be supported by a three pile cluster, or if a four pile cluster was required.

The factored base shear on any column was determined to be 21.89 Kip less than 30 Kips the shear capacity of three piles. Therefore based on shear loading three piles was sufficient for every column.

To determine the axial and compression load per pile for the three pile caps it was assumed the column axial load was evenly distributed among the piles and that the moment was resisted by a couple of equal amounts on tension on one side of the pile cap and compression on the other side of the pile cap. In the case of the three pile clusters, it was assumed that the pile caps were oriented in such a way that one pile on each side took all of the tension or compression generated by the moment at the base of the column and that the third pile was located at the neutral axis and thus only took axial compression. It was assumed that the forces resulting from the column moment were resisted by two piles on each side. Figure 51 depicts the pile loading assumptions.

The piles supporting the shear walls were assed in a similar manor to the piles supporting the columns.

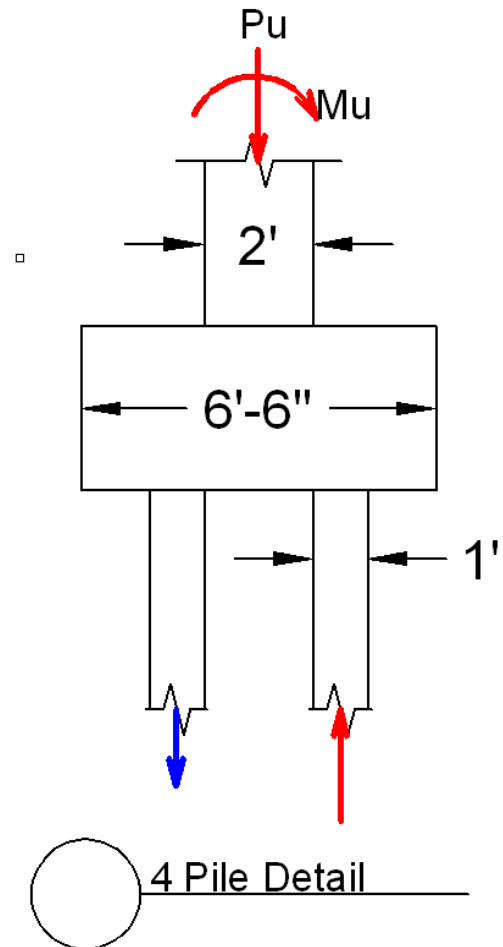
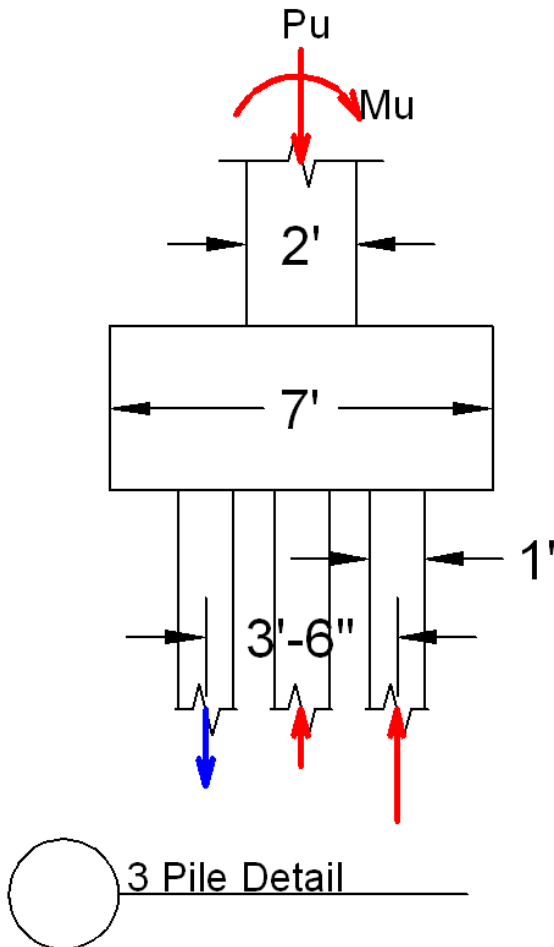
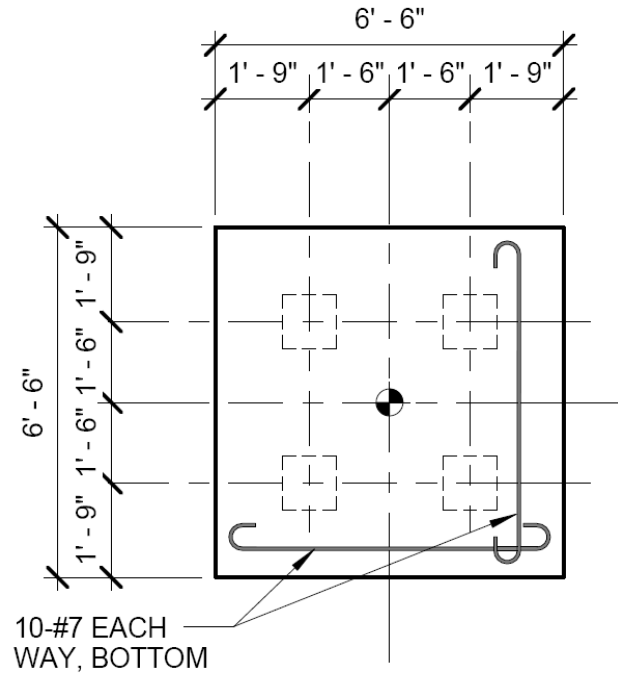
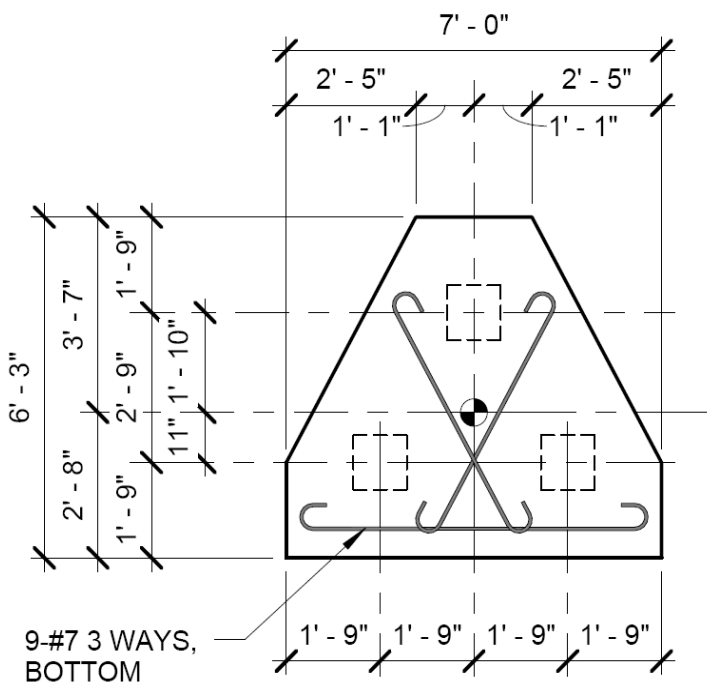

Figure 51

| Column Foundation Requirement Analysis | | | | | | | | | | |
|----------------------------------------|---------------------------------|-----------------------------------|--------------------------|--------|---------------------------------|-----------------------------------|--------------------------|--------|------------------------|---------------------|
| Sign Convention (+Comp./-Tension) | 3 Piles | | | | 4 Piles | | | | Original # of Piles | Final # of Piles |
| | Critical Comp. Load (K/Pile) | Critical Tensile Load (K/Pile) | P<P _{Allowable} | Uplift | Critical Comp. Load (K/Pile) | Critical Tensile Load (K/Pile) | P<P _{Allowable} | Uplift | | |
| Column Location | | | | | | | | | | |
| 1,0,A | 23.44 | 4.08 | OK | NO | 19.07 | 2.69 | OK | NO | 2 | 2 |
| 1.1,0,A | 18.94 | -8.73 | OK | YES | 18.56 | -10.90 | OK | YES | 1 | 1 |
| 1.2,0,A | 35.74 | 13.68 | OK | NO | 28.28 | 10.01 | OK | NO | 2 | 2 |
| 1,E,5 | 25.95 | 6.22 | OK | NO | 21.54 | 4.44 | OK | NO | 2 | 2 |
| 1,F | 22.11 | 4.36 | OK | NO | 19.15 | 1.36 | OK | NO | 2 | 2 |
| 1.1,E,5 | 28.08 | -7.90 | OK | YES | 26.62 | -10.11 | OK | YES | 1 | 1 |
| 1.2,E,6 | 40.21 | 11.64 | OK | NO | 33.01 | 7.36 | OK | NO | 2 | 2 |
| 1.2,F | 17.60 | -12.54 | OK | YES | 14.71 | -12.92 | OK | YES | 2 | 2 |
| 1.8,A,1 | 71.42 | 25.39 | OK | NO | 53.87 | 18.20 | OK | NO | 3 | 3 |
| 1.9,A,2 | 60.31 | 18.72 | OK | NO | 48.20 | 13.28 | OK | NO | 3 | 3 |
| 1.9,E,6 | 61.40 | 19.37 | OK | NO | 48.60 | 13.53 | OK | NO | 0 | 3 |
| 1.9,F | 26.07 | 6.13 | OK | NO | 21.09 | 4.39 | OK | NO | 0 | 3 |
| 2,B | 81.21 | 21.10 | OK | NO | 63.80 | 12.57 | OK | NO | 4 | 3 |
| 2,C | 75.67 | 12.85 | OK | NO | 60.16 | 5.29 | OK | NO | 4 | 3 |
| 3,B | 139.86 | 51.23 | OK | NO | 107.05 | 36.72 | OK | NO | 4 | 3 |
| 3,C | 140.71 | 43.60 | OK | NO | 110.07 | 29.39 | OK | NO | 4 | 3 |
| 4,B | 135.67 | 49.40 | OK | NO | 104.06 | 35.61 | OK | NO | 4 | 3 |
| 4,C | 116.36 | 34.70 | OK | NO | 92.62 | 23.46 | OK | NO | 4 | 3 |
| 6,B | 135.87 | 48.43 | OK | NO | 103.97 | 34.40 | OK | NO | 4 | 3 |
| 6,C | 99.79 | 32.19 | OK | NO | 76.57 | 22.47 | OK | NO | 4 | 3 |
| 6,D | 73.63 | 20.05 | OK | NO | 58.20 | 13.45 | OK | NO | 3 | 3 |
| 7,B | 143.35 | 52.21 | OK | NO | 109.36 | 37.07 | OK | NO | 4 | 3 |
| 7,C | 105.38 | 28.12 | OK | NO | 83.32 | 17.84 | OK | NO | 4 | 3 |
| 7,D | 56.94 | 16.09 | OK | NO | 44.00 | 10.47 | OK | NO | 2 | 2 |
| 8,B | 105.22 | 31.83 | OK | NO | 82.60 | 20.02 | OK | NO | 4 | 3 |
| 8,C | 89.12 | 16.24 | OK | NO | 71.05 | 8.69 | OK | NO | 4 | 3 |
| 8,D | 36.57 | 8.11 | OK | NO | 28.81 | 3.74 | OK | NO | 2 | 2 |
| 8.1,0,A | 39.82 | 12.16 | OK | NO | 32.42 | 7.72 | OK | NO | 4 | 4 |
| 9,0,A | 29.72 | 11.91 | OK | NO | 22.97 | 8.62 | OK | NO | 3 | 3 |
| 9,B | 49.91 | 2.17 | OK | NO | 44.09 | -4.12 | OK | YES | 0 | 3 |
| 2.1,F | 58.74 | 17.69 | OK | NO | 44.52 | 12.35 | OK | NO | 2 | 2 |
| 3.1,F | 37.33 | 13.45 | OK | NO | 29.37 | 9.05 | OK | NO | 2 | 2 |
| 3.8,F | 43.99 | 9.24 | OK | NO | 36.28 | 5.33 | OK | NO | 3 | 3 |
| 4.1,E | 92.81 | 26.85 | OK | NO | 74.12 | 17.78 | OK | NO | 3 | 3 |
| 4.1,F | 59.06 | 22.06 | OK | NO | 45.62 | 15.17 | OK | NO | 3 | 3 |
| 5,E | 80.78 | 32.39 | OK | NO | 60.65 | 24.21 | OK | NO | 3 | 3 |
| 4.9,F | 55.53 | 16.46 | OK | NO | 42.15 | 11.86 | OK | NO | 3 | 3 |
| 5.5,E | 98.69 | 28.55 | OK | NO | 76.50 | 19.49 | OK | NO | 3 | 3 |
| 5.5,F | 94.03 | 25.37 | OK | NO | 77.02 | 15.40 | OK | NO | 3 | 3 |
| 6.6,E | 91.55 | 29.70 | OK | NO | 73.31 | 22.08 | OK | NO | 3 | 3 |
| 6.6,F | 60.48 | 24.83 | OK | NO | 45.70 | 17.51 | OK | NO | 3 | 3 |

Figure 52

| Shear Wall Foundation Analysis | | | | | | | | |
|--------------------------------|---------------------------------|-----------------------------------|---------------------------------|--------------------------|--------------------------|--------|------------------------|---------------------|
| Wall | Critical Comp. Load (K/Pile) | Critical Tensile Load (K/Pile) | Critical Shear Load (K/Pile) | P<P _{Allowable} | V<V _{Allowable} | Uplift | Original # of Piles | Final # of Piles |
| SW 1, SW 3, SW 5, & SW7 | | | | | | | 22 | 0 |
| SW 2 | 77 | -29 | 9 | OK | OK | YES | 10 | 10 |
| SW 4 | 142 | -27 | 12 | OK | Fail* | YES | 10 | 10 |
| SW 6 | 61 | -21 | 8 | OK | OK | YES | 12 | 12 |

Figure 53

The foundation analysis revealed that under the loading of the redesigned structure all of the columns could be supported three pile clusters. The shear wall foundation analysis revealed that, with the same number of piles as in the original design, compressive and tensile pile capacities were not exceeded. The shear wall foundation analysis also determined that the allowable shear capacity of piles supporting Shear Wall 4 were exceed based on the assumption that the entirety of the column base shear must be resisted by the piles. A chart comparing the base shears that Shear Wall 4 was subjected to in the original and redesigned structure was made.

| Shear Wall Base Shear Comparison Chart | | | | | |
|-----------------------------------------------|-------------|------------------------------|---------|-------------|---------|
| Original Base Shear | | New Design Base Shear | | | |
| Seismic | Wind | Seismic | | Wind | |
| (Kips) | (Kips) | (Kips) | % Orig. | (Kips) | % Orig. |
| 72 | 99 | 62 | 86% | 95 | 96% |
| 129 | 162 | 106 | 82% | 158 | 98% |
| 102 | 81 | 67 | 66% | 77 | 95% |

Figure 54

The comparison revealed that both under seismic and wind loading the base shear at Shear Wall 4 was smaller in the new design than the original. It was therefore concluded that the grade beam connected to the pile cap below Shear Wall 4 was designed to take a portion of the walls base shear in the original design and therefore piles did not need to be added in the new design.

In summation foundation analysis of the redesigned structural system determined that it is structurally feasible to reduce the number of piles clustered below typical columns from four to three. Furthermore, the foundation analysis found that the foundations supporting the three remaining shear walls in the redesigned structural system did not need to be increased.

Figure 55 summaries the reduction in the number piles supporting the Game Day Building.

| Foundation Redesign Summary | | | |
|------------------------------------|----------------------------|-------------------------|-------------------|
| Supporting | Original # of Piles | Final # of Piles | Difference |
| Columns | 113 | 110 | -3 |
| Shear Walls | 54 | 32 | -22 |
| Façade | 16 | 16 | 0 |
| Total | 183 | 158 | -25 |

Figure 55

Structural Depth Conclusions

A very thorough analysis of the effects of replacing the Game Day Building's existing floor system with a floor system comprised on one-way reinforced concrete slabs supported by post tensioned concrete beams was conducted.

It was determined that if edge beams were provided along cantilevers a reduction in slab depth from 12" to 7" was permissible throughout the entire building.

A beam depth of 14", twice the depth of the one-way slabs and an increase of only 2" from the original flat plate depth, was determined to be sufficient for the majority of the beams throughout the building. Along the South façade of the building and in a few other locations where it was determined that an increase in beam depth would be preferable to an increase in width 18" deep beams were used.

The process of creating and designing with an Excel file capable of quickly analyzing post tensioned beams for multiple design criteria developed a very detailed and through understanding of the structural design procedures associated with post tensioning.

By taking advantage of the typical bay aspect ratios and the shallows beam sections possible with post tensioning the amount of concrete used in the gravity system was reduced by over 30%.

Due to the Game Day Building's relatively low height and location in a non seismicly active region the lateral loads it is subjected to are typically less critical in determining member sizes than gravity loading. This became very apparent when the effects of combined lateral and gravity loading on the post tension beams were considered and in nearly all the beams the critical moments were generated by the 1.2D+1.6L load combination.

The number of shear walls was able to be significantly reduced due to the addition of the beams in the East/West plan direction and the relatively load magnitude of lateral loads the Game Day Building was subjected to.

Analysis of the foundations revealed that with the decrease in dead loads, the redesign of the elevated floor systems the majority of four pile clusters could be reduced to three pile clusters.

All the structural goals set forth in the proposed solutions to the possible improvements to the original design of the Game Day Building were accomplished successfully.

BREADTH STUDIES

Construction Management Study: A construction management breadth study will be performed to determine the ramifications of the structural redesign in terms of cost and schedule changes.

Lighting Breadth Study: A lighting breadth study will be performed to develop an alternate lighting system in the scholarship lounge to create a more upscale ambiance.

Construction Management Breadth

Problem Statement

Changing the foundations, floor slabs, and lateral system will clearly have major effects on the cost, constructability, and schedule of a building. Understanding the effects of the proposed structural redesigns on construction management issues is necessary to determine their structural systems feasibility.

Proposed Solution

Conduct cost and schedule analyses comparing of the existing structure and the proposed redesigned version of the structure.

- Determine if the more structurally efficient designs achieved with by post tensioning offset the costs associated with its use.
- Develop an efficient construction sequence that satisfies the unique demands of post tensioning
- Determine if the addition of post tensioning to the structure increase the construction schedule duration into past the start of the 2009 football season.

Cost analysis

Detailed material takeoffs of the structural systems of both the existing design and the redesigned structure were performed. RSMMeans 2009 costs modified by location factors for Norfolk VA were then used to determine the material, labor, and equipment costs associated with the construction of the structures. Figure 56 shows the material quantities determined to present in the floor systems in the original and new design of the structure. Similar tables summarizing the material quantities determined to be present in the columns and shear walls are available upon request.

| Beams & Slabs | | | | | | | | | |
|-----------------|----------|------|---------------|------|-----------------------------|---------------|---------------|-----------------------------|--|
| New Design | | | | | | | | | |
| Floor | Concrete | PT | Beam Formwork | Beam | Beam Mild Steel Reinforcing | Slab Formwork | Slab Concrete | Slab Mild Steel Reinforcing | |
| | yd^3 | lbs | SFCA | C.Y. | lb | SFCA | C.Y. | lb | |
| 2nd Floor | 455 | 2917 | 3949 | 107 | 25388 | 13477 | 348 | 44524 | |
| 3rd Floor | 387 | 2663 | 3758 | 101 | 20814 | 10704 | 285 | 36501 | |
| 4th Floor | 312 | 2321 | 2882 | 78 | 17069 | 8899 | 234 | 29935 | |
| Roof | 239 | 1622 | 2095 | 57 | 13784 | 7023 | 182 | 24173 | |
| Total | 1392 | 9522 | 12685 | 343 | 77055 | 40104 | 1049 | 135134 | |
| Original Design | | | | | | | | | |
| Floor | Concrete | PT | Beam Formwork | Beam | Beam Mild Steel Reinforcing | Slab Formwork | Slab Concrete | Slab Mild Steel Reinforcing | |
| | yd^3 | lbs | SFCA | C.Y. | lb | SFCA | C.Y. | lb | |
| 2nd Floor | 593 | 0 | 1208.25 | 51 | 9242 | 14901.75 | 541 | 97184 | |
| 3rd Floor | 521 | 0 | 990.75 | 31 | 7577 | 12219.25 | 489 | 79674 | |
| 4th Floor | 427 | 0 | 811.5 | 26 | 6214 | 10008.5 | 401 | 65341 | |
| Roof | 345 | 0 | 631.5 | 33 | 5018 | 7788.5 | 312 | 52765 | |
| Total | 1885 | 0 | 3642 | 142 | 28052 | 44918 | 1743 | 294964 | |

Figure 56

| Structural System Cost Comparison Summary | | | |
|-------------------------------------------|-----------------|-------------|-----------------|
| Material | Original Design | New Design | Cost Difference |
| Elevated Structural System Unit Costs | | | |
| Concrete Formwork | \$520,323 | \$497,533 | -\$22,790 |
| Reinforcing steel | \$596,631 | \$404,878 | -\$191,753 |
| Prestressing Steel | \$0 | \$16,188 | \$16,188 |
| Concrete | \$336,597 | \$298,460 | -\$38,137 |
| Concrete Placing | \$49,331 | \$47,675 | -\$1,655 |
| Assemblies Costs | | | |
| Deep Foundations | \$851,525 | \$738,506 | -\$113,019 |
| Shallow Foundations | 132684.27 | \$120,328 | -\$12,356 |
| Slab on Grade | \$77,776 | \$77,776 | \$0 |
| Total | \$1,502,882 | \$1,264,735 | -\$238,147 |

Figure 57

Based on RSMeans construction pricing the proposed redesign of the structure would cost \$238,147 less than the original design, a savings of approximately 16%. Figures in Appendix B give a more detailed breakdown of the cost analysis.

Schedule Analysis

After the cost analysis was completed, a PDF copy of a schedule for the construction of the Game Day Building was analyzed. The PDF of the schedule showed task descriptions, task durations and early start and early finish dates. Based on the stated task start and finish dates logic connecting the tasks was deduced and added to the Microsoft Project schedule. A detailed critical path was then determined throughout the building’s main structural system construction phases. The connections relating the buildings overall substantial completion and the structural construction tasks were then determined.

The task durations listed in the PDF were sometimes shorter than the number of typical work days between the early start and early finish dates. These task duration discrepancies were dealt with by assuming the stated task durations, which were relatively consistent from floor to floor were correct and then adding a task representing the total structural float time of 35 days to the end of the structural construction schedule.

With a working logical schedule for the original design created, attention was turned to the modifications that would need to be made to the schedule to take into account the addition of post tensioning to the structure. Due to the overall length of the building being nearly 300' it was required to tension the post tensioning tendons in multiple locations along the length of the building. In order to minimize schedule expansion it was determined that the construction should be broken up into three sequences per floor. In the schedule provided for the original design construction of the floors were not broken up into multiple sequences.

In order to reduce effective prestress losses in the approximately 220' long continuous tendon strips on East half of the building it was decided to “dead end” anchor the tendons just to the west of grid line 5. Concrete would then be poured on one side of the anchorage, allowed to cure, and have the tendons in it stressed. By doing this elastic shrinkage on half of the slab occurs before the tendons are jacked on the other side. This results in less of the elongation of the second set of tendons being lost after jacking. It was determined that the most time effective erection sequence that allowed this to occur was to first place the concrete in the middle of the building. Second, leaving a temporary pour strip between gridlines 1.9 and 2 to allow access for jacks, place the concrete on the East side of the building. Lastly, place the concrete on the West side of the building. This sequence of concrete placement provides the most time for the concrete in the middle of the building to be jacked and allowed to elastically shorten before concrete is placed in the adjoining slab to West. Figure 58 depicts this sequence of construction on the second floor.

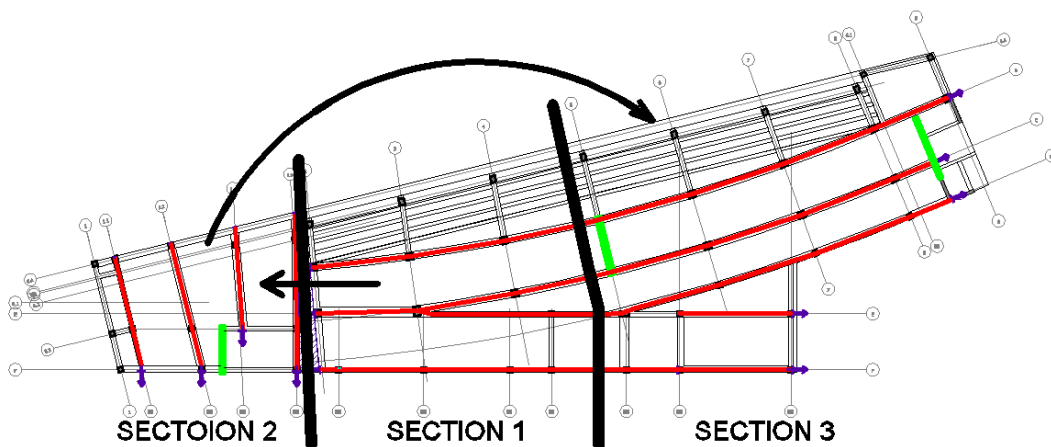

Figure 58

Figure 59 shows the structural schedule for the third floor in the original design.

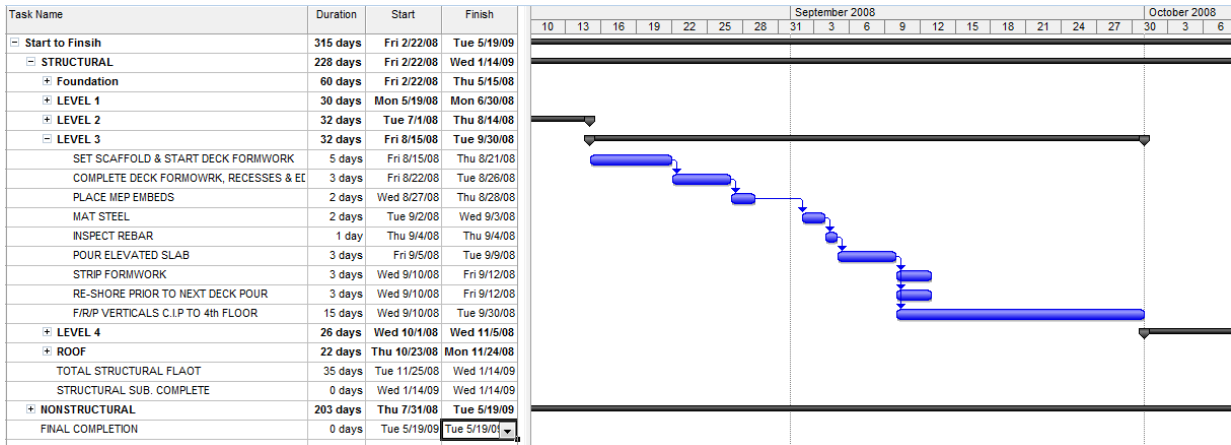

Figure 59

The schedule provided for the Game Day Building does not break the construction of each floor into multiple sections. Rather, it schedules each task to be done for an entire floor at time. This leads to a large portion of the tasks being part of the critical path. The resulting duration for completing all the structural construction tasks on the third floor is 32 Days. Figure 60 shows the structural schedule created for the post tensioned design.

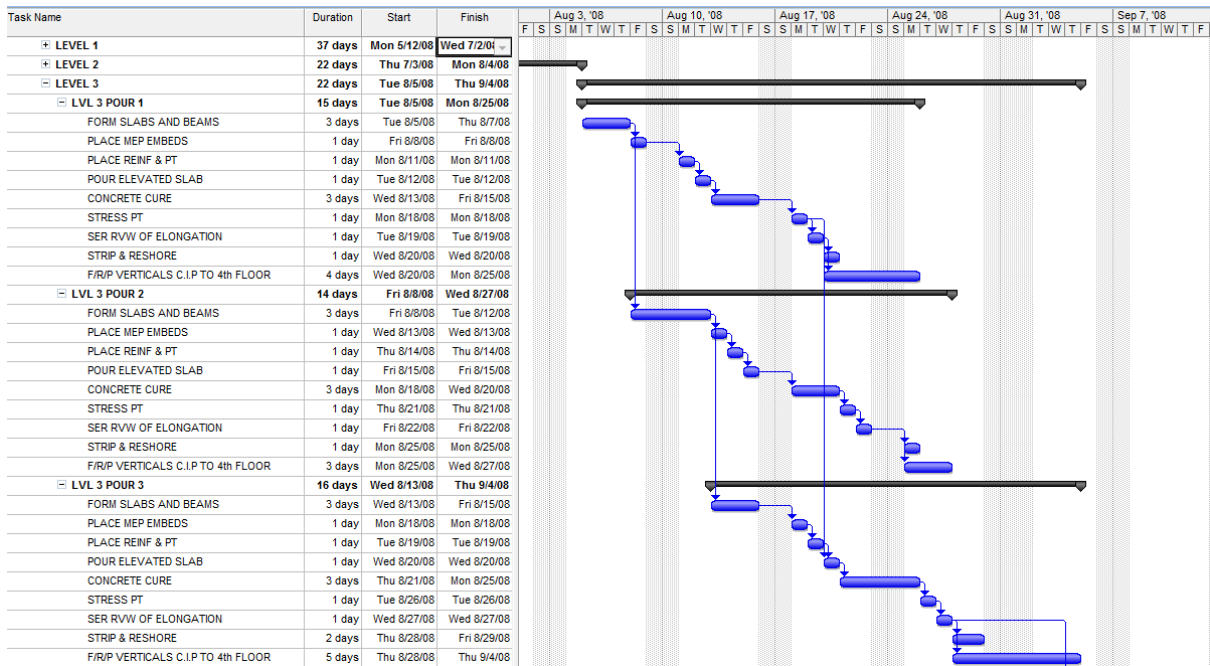

Figure 60

The use of post tensioning in the floor system creates additional steps in the erection process. Specifically, after the concrete is placed it must be allowed to cure for three days to allow it to reach a compressive strength of 3000 psi. On the fourth day after the slab is placed the tendons embedded in the slab are tensioned with jacks that elongate the tendons to a specified value. Depending on the municipality in which the project is constructed, or a variety of other factors, an inspection to verify the tendon jacking was properly conducted may be required. The schedule assumes that such a check needs to be performed before the floor can be stripped and reshored. These additional steps increase the amount of time required to complete a floor section. By breaking up the construction of each floor into three sequences and overlapping tasks performed in each section the duration required to erect the structure is reduced. The task with the single longest duration for each floor in the original structural schedule was the forming reinforcing and placing of vertical members to the story above. The removal of four of the seven shear walls in the redesigned lateral system noticeably reduces time required to perform this task. The combination of overlapping construction sequences and having fewer shear walls more than helps recoup the time added by post tensioning.

Figures 61 and 62 below show the condensed schedules for the original and redesigned versions of the Game Day Building.

Original Design Schedule Summary

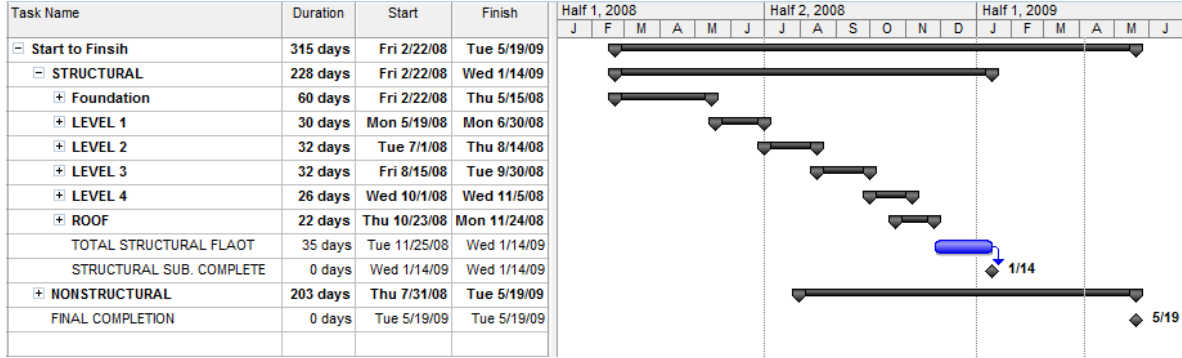

Figure 61

New Design Schedule Summary

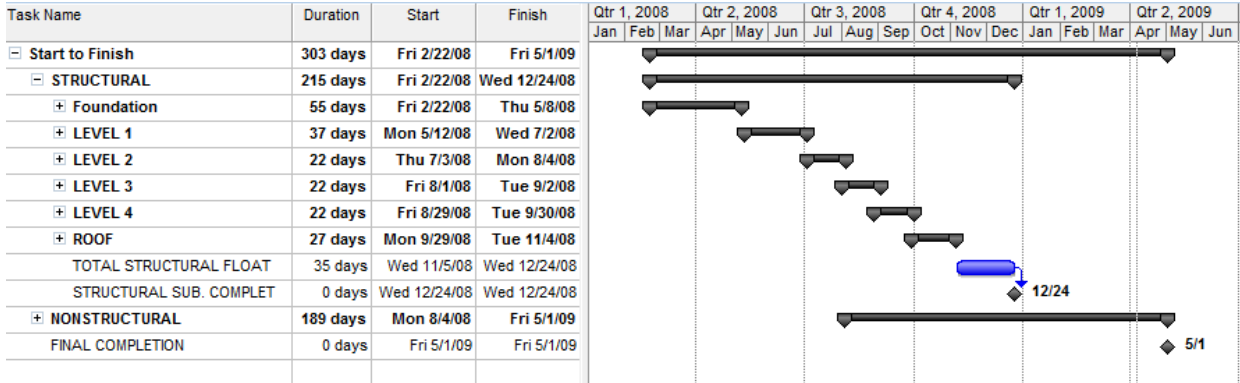

Figure 62

Construction Management Breadth Conclusions

Based on RSMeans values the additional costs of prestressing tendons and high early strength concrete in the redesigned structural system were more than made up for by the reduction in quantities of milled steel, cubic yards of concrete, and formwork required for shear walls post their use permitted. The estimated cost savings of \$238,000 are a 16% reduction of the cost of the structural system and a 2% reduction in cost of the entire project.

As can be seen in their respective schedules, shown in full in Appendix B, by overlapping sequences, reducing the number of shear walls, and reducing the number of piles the proposed post tensioned design of the Game Day Building can theoretically be constructed 13 days quicker than the two-way flat plate design. It is therefore safe to say that post tensioning can be incorporated in the structure of the Game Day building without extending the project duration into the fall football season.

The cost and schedule analyses performed found the proposed post tensioned design of the game day building to be preferable to the original two-way flat plate design.

Lighting Breadth Study

Problem Statement

The decision of who to award the contract for the design and construction of the Game Day Building was likely based primarily on submittals of initial designs and cost estimate of by multiple teams of design and construction firms. The team with the lowest price building design had a very good chance of winning the contract. It was therefore the objective of the original lighting designer to satisfy the minimal lighting requirements for the lowest price possible. If low price had not been a driving design concern a more attractive lighting scheme could likely have been achieved.

Proposed Solution

The scholarship lounge on the East side of the second floor is one area of the Game Day Building intended to be used for more than just watching football games. Located adjacent to the kitchen the scholarship lounge could very easily be used as location for catered parties and presentations throughout the year. An alternate lighting system will be developed for the scholarship lounge with the goal of creating a more upscale atmosphere in which parties and presentations can be held. Objectives of the alternate lightings system is intended to achieve are as follows.

- Integrate the structural redesign into the redesigned lighting scheme
- Make the room seem more spacious have emphasizing the peripherals by having a high luminance on the Walls and Ceiling.
- Increase flexibility by specifying dimmable fixtures
- Satisfy ASHRE 90.1 energy consumption limits
- Reach IESNA Lighting Handbook recommended illumiance levels
- Use attractive or concealed luminaries

Lighting Plan and Fixture Schedule

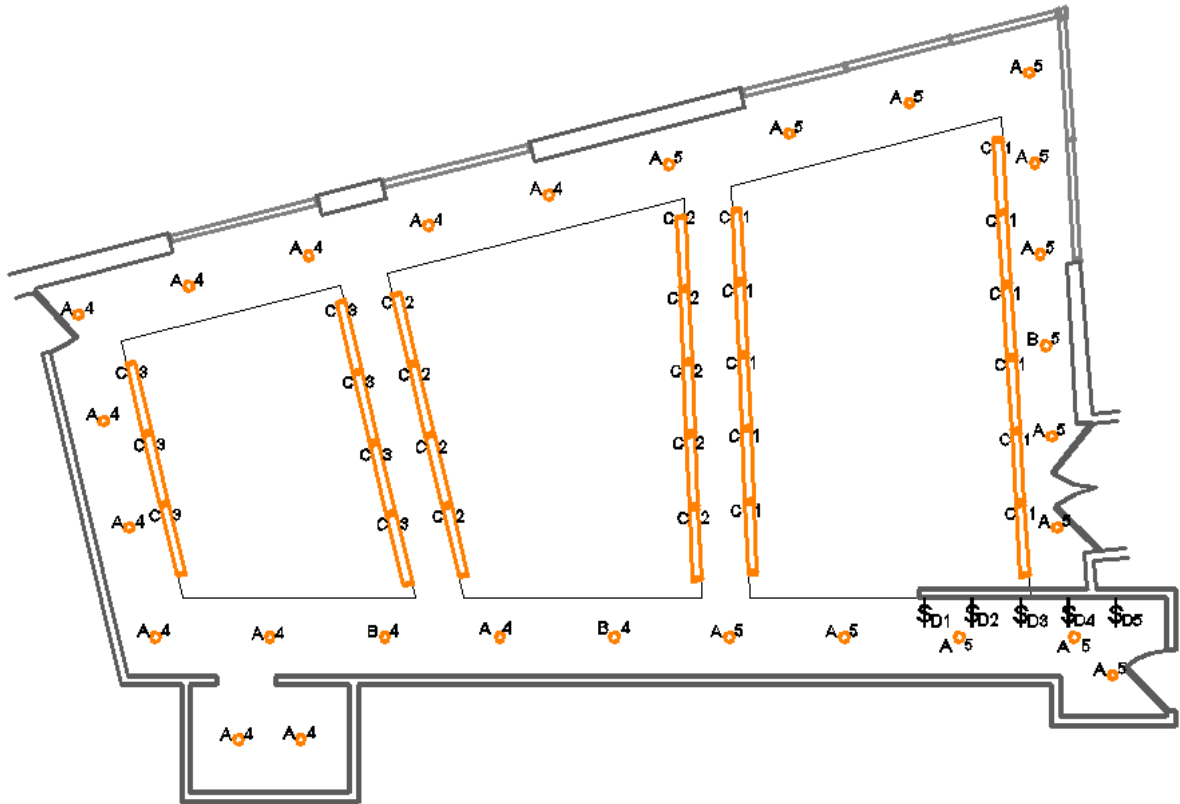

Figure 63

| Lighting Fixture Schedule | | | | |
|---------------------------|--------------|----------------------------|--------------------------------------------|-----------------|
| Luminaire | | | | |
| Fixture Type | Manufacturer | Model | Fixture Description | |
| A | Indy | FD16-32E-SACSF-LD | 6" Triple Tube Vertical 1-Lamp Downlight | |
| B | Indy | FW16-32E-SACSF-LD | 6" Triple Tube Vertical 1-Lamp Wall Wash | |
| C | Williams | AIWP33-8-232T8-C1B-EB2-277 | Architectural Indirect Wall Mount | |
| Ballast | | | | |
| Fixture Type | Manufacturer | Model | Ballast Description | Ballast Current |
| A | Lutron | FDB-T432-277-1-S | Compact SE Electronic Dimming Ballast | 0.12A |
| B | Lutron | FDB-T432-277-1-S | Compact SE Electronic Dimming Ballast | 0.12A |
| C | Lutron | ECO-T832-277-1-L | Eco Electronic Dimming Ballast | 0.14A |
| Lamp | | | | |
| Fixture Type | Manufacturer | Model | Lamp Description | Watts |
| A | Phillips | PL-T032W-835-4P-1CT | 4pin 3 tube CFL | 32 W |
| B | Phillips | PL-T032W-835-4P-1CT | 4pin 3 tube CFL | 32 W |
| C | Phillips | F32T8 ADV835 ALTO | T8-Eco | 32 W |
| Switching | | | | |
| Fixture Type | Manufacturer | Model | | SWITCH CAPACITY |
| A | Lutron | DVF-103P-277-WH | Large paddle switch w/ linear-slide dimmer | 6A |
| B | Lutron | DVF-103P-277-WH | Large paddle switch w/ linear-slide dimmer | 6A |
| C | Lutron | DVF-103P-277-WH | Large paddle switch w/ linear-slide dimmer | 6A |

Figure 64

Spec. sheets for all components listed in the lighting fixture schedule are available upon request.

Quantitative Design

Using AGI to perform the lighting calculations the average illuminance on a horizontal task plan located 2'-6" above the floor was found to be 31 foot-candles, greater than the IESNA prescribed 30 foot-candles requirement. The lighting system designs power density is 0.983Watts/ft² less than the ASHRE 90.1.2007 limits.

| Power Consumption Limits | |
|-----------------------------|---------------------------------|
| ASHRE 90.1 2007 Table 9.5.1 | |
| Building Area | Permitted Watts/ft ² |
| Sports Arena | 1.1 |
| ASHRE 90.1 2007 Table 9.6.1 | |
| Space Description | Permitted Watts/ft ² |
| Lounge/Recreation | 1.2 |

Figure 65

| Light Loss Factor Assumptions | |
|-------------------------------|------|
| Lamp Lumen Depreciation | 0.90 |
| Luminaire Dirt Depreciation | 0.90 |
| Ballast Factor | 1.00 |
| Total Light Loss Factor | 0.81 |

Figure 66

| Required Illuminance 9th Ed. IESNA Lighting Hand Book Figure 10-9 | |
|----------------------------------------------------------------------|--------------------|
| Task | Lounge and Reading |
| Horizontal Illuminance Category | D |
| Vertical Illuminance Category | N/A |
| Required Foot Candles @ Task Plane | 30 |

Figure 67

Iso Line Illuminance Plan

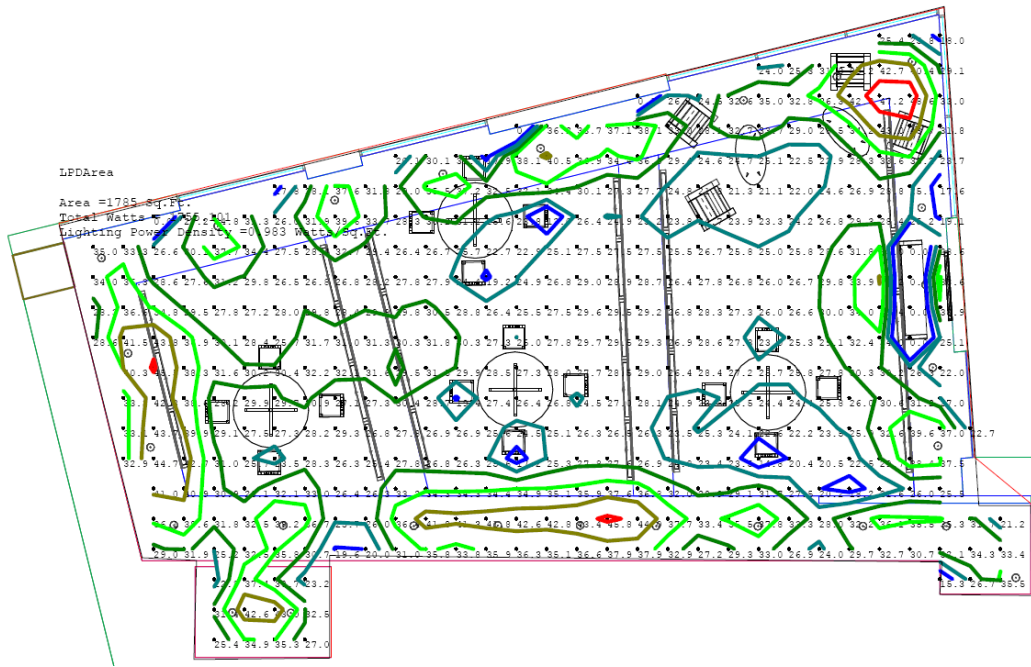

Figure 68

Renderings

Existing Design Rendering



Figure 69

Alternate Design Rendering



Figure 70

Pseudo Color Illuminance Rendering

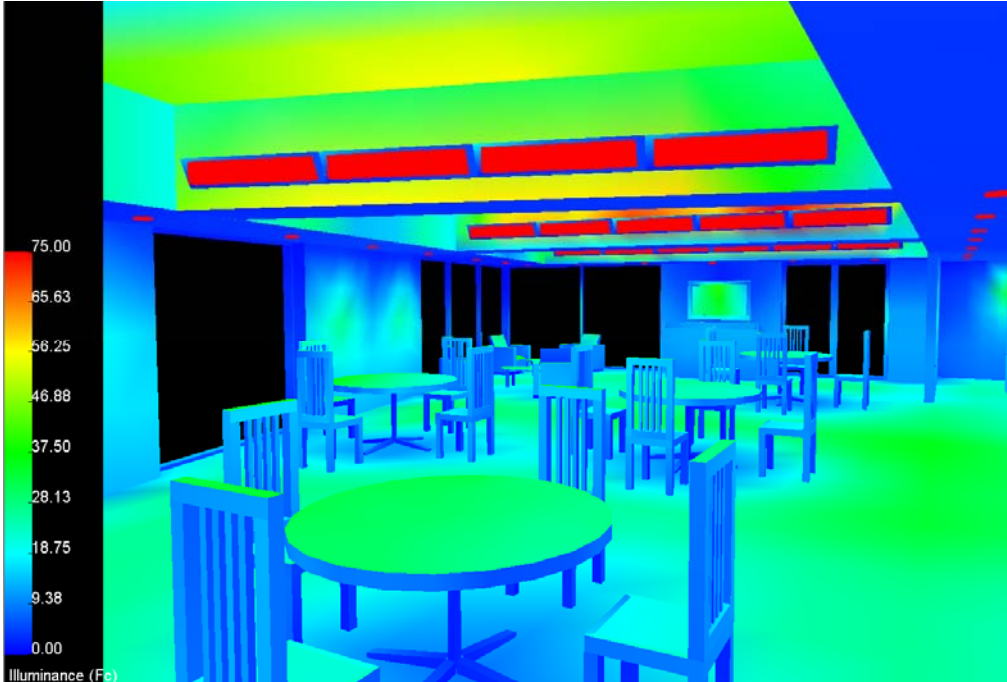

Figure 71

Black and White Rendering



Figure 72

Lighting Breadth Conclusions

An alternate lighting design for the Game Day Building's Scholarships lounge that satisfied both the required illuminance and power density requirements was created. The Game Day Building's structural redesign was incorporated into the new lighting design through the use of wall mounted indirect luminaires attached to soffits concealing the beams. The structural redesign was also the catalyst allowing the ceiling height between the beams to be increasing significantly. This increase in height of the ceiling above the soffit height allowed the indirect wall mounted luminaires to better project light over a much greater area of the ceiling. The ceiling being well lit, in conjunction with the 6" diameter wall washing CFL cans emphasizing artwork on the walls, helped to make the room seem more spacious.

MASTERS LEVEL CLASS INFLUENCE

The creation of ETABS models used extensively in the design and analysis of the Game Day Building's lateral system was possible because of the material covered in AE597A

CONCLUSIONS

The proposed structural redesigns of Game Day Building were all completed successfully. By switching from two-way slabs to one-way slabs the typical slab depth was reduced from twelve inches to seven inches. By using post tensioning tendons in the beams supporting the one way slabs, a shallow typical beam depth of fourteen inches was achieved.

The inherent concrete moment frames created by the post tensioned beams sized to resist gravity loads were determined to be sufficiently stiff to remove the majority of the shear walls from the building without exceeding code prescribed deflection limits.

Analysis of the foundations revealed that 25 fewer piles were needed to support the Game Day Building if the proposed changes were made to the gravity and lateral systems.

A cost comparison of the original and the redesigned versions of the game day building concluded that the proposed structural redesigned would decrease the price of the structure by 16%. Schedule analysis determined that if proper sequencing were used post tensioning would not increase the amount of time required to construct the Game Day Building.

The decrease in slab depth facilitated the design of an eye catching lighting system in the scholarship lounge that satisfied both IESNA and ASHRE requirements.

In conclusion all the proposed alterations to the Game Day Building were successfully accomplished.

ACKNOWLEDGMENTS

The following individuals were of immeasurable assistance in preparation of this report.

- | | |
|-------------------|--------------------------|
| Rich Apple | Holbert Apple Associates |
| Peter A. Allen | Clark Nexsen |
| Brian M. Barna | Clark Nexsen |
| Alicia B, Udovich | Clark Nexsen |
| John Wilson | Clark Nexsen |

APPENDICES

Appendix A Structural

The columns shaded in tan represent user specified input. The values in the non-shaded cells are automatically calculated.

| Material Properties | | | | | | | | | | | | | |
|---------------------|------|-------|-----|-----|-----|--------|--------|-----|----------|----------|-------|-------|-----|
| f'c | f'ci | fy | fpu | fpv | fpi | Losses | η | fpe | Ec | Eci | Es | Ep | γc |
| psi | psi | ksi | ksi | ksi | ksi | ksi | % | ksi | ksi | ksi | ksi | ksi | pcf |
| 6000 | 3000 | 60000 | 270 | 243 | 189 | 15 | 92.06% | 174 | 4415.201 | 3122.019 | 29000 | 27000 | 150 |

| Beam | Overall Span Geomtry | | | | Moment Distribution | | | Gravity Loading | | | | | | | | | | |
|-------------|----------------------|------------|----------------|-------|---------------------|---------------|----------------------------------|-----------------|----------|---------------------|-------|-------|--------------------------|------------------|-----------------|-----------------|----------------|----------------|
| | OC Span | Clear Span | Slab Supported | | Col. (A) Width | Col.(B) Width | Moment Distribution Coefficients | | | Supperimposed Loads | | | Design Distributed Loads | | | | | |
| | | | Width | Depth | | | Col. (A) | Midspan | Col. (B) | SDL | SDL | LL | W _D | W _{SDL} | W _{LL} | W _{BI} | W _B | W _U |
| ft | ft | ft | in | in | in | w*ln^2/? | w*ln^2/? | w*ln^2/? | psf | plf | psf | k/ft | k/ft | k/ft | k/ft | k/ft | k/ft | |
| B,2-3 | 30.5 | 28.5 | 11.1 | 7.0 | 24.0 | 24.0 | 12.8 | 23.3 | 11.6 | 5.0 | 100.0 | 1.18 | 0.06 | 1.11 | -1.01 | -0.93 | 3.26 | |
| B,3-4 | 30.5 | 28.5 | 12.3 | 7.0 | 24.0 | 24.0 | 12.1 | 24.0 | 11.9 | 5.0 | 100.0 | 1.28 | 0.06 | 1.23 | -1.09 | -1.00 | 3.58 | |
| B,4-5 | 30.5 | 28.5 | 12.8 | 7.0 | 24.0 | 24.0 | 12.0 | 24.0 | 12.0 | 5.0 | 100.0 | 1.32 | 0.06 | 1.28 | -1.18 | -1.09 | 3.71 | |
| B,5-6 | 30.5 | 28.5 | 12.8 | 7.0 | 24.0 | 24.0 | 12.0 | 24.0 | 12.0 | 5.0 | 100.0 | 1.32 | 0.06 | 1.28 | -1.18 | -1.09 | 3.71 | |
| B,6-7 | 30.5 | 28.5 | 12.3 | 7.0 | 24.0 | 24.0 | 11.9 | 24.0 | 12.1 | 5.0 | 100.0 | 1.28 | 0.06 | 1.23 | -1.09 | -1.00 | 3.58 | |
| B,7-8 | 30.5 | 28.5 | 11.1 | 7.0 | 24.0 | 24.0 | 12.0 | 24.3 | 11.8 | 5.0 | 100.0 | 1.18 | 0.06 | 1.11 | -1.03 | -0.94 | 3.26 | |
| B,8-9 | 25.3 | 23.3 | 17.3 | 7.0 | 24.0 | 24.0 | 9.6 | 18.7 | 26.1 | 5.0 | 100.0 | 1.71 | 0.09 | 1.73 | -1.47 | -1.36 | 4.92 | |
| C,2-3 | 31.4 | 29.4 | 17.4 | 7.0 | 24.0 | 24.0 | 12.9 | 22.6 | 11.9 | 5.0 | 426.8 | 1.81 | 0.09 | 1.74 | -1.56 | -1.44 | 5.06 | |
| C,3-4 | 31.4 | 29.4 | 10.5 | 7.0 | 24.0 | 24.0 | 11.6 | 24.7 | 12.1 | 5.0 | 100.0 | 1.12 | 0.05 | 1.05 | -0.93 | -0.86 | 3.09 | |
| C,4-5 | 31.4 | 29.4 | 12.5 | 7.0 | 24.0 | 24.0 | 12.2 | 24.0 | 11.8 | 5.0 | 100.0 | 1.30 | 0.06 | 1.25 | -0.93 | -0.86 | 3.63 | |
| C,5-6 | 31.4 | 29.4 | 15.0 | 7.0 | 24.0 | 24.0 | 12.1 | 23.9 | 11.9 | 5.0 | 100.0 | 1.51 | 0.07 | 1.50 | -1.12 | -1.03 | 4.30 | |
| C,6-7 | 31.4 | 29.4 | 15.0 | 7.0 | 24.0 | 24.0 | 12.0 | 24.0 | 12.0 | 5.0 | 100.0 | 1.51 | 0.07 | 1.50 | -1.12 | -1.03 | 4.30 | |
| C,7-8 | 31.4 | 29.4 | 15.0 | 7.0 | 24.0 | 24.0 | 11.8 | 23.5 | 12.6 | 5.0 | 100.0 | 1.51 | 0.07 | 1.50 | -1.12 | -1.03 | 4.30 | |
| C,8-9 | 13.7 | 11.7 | 15.0 | 7.0 | 24.0 | 24.0 | 6.9 | 35.7 | 20.4 | 5.0 | 100.0 | 1.51 | 0.07 | 1.50 | -1.16 | -1.07 | 4.30 | |
| E,3-4.1 | 39.0 | 37.3 | 10.9 | 7.0 | 24.0 | 18.0 | 11.6 | 23.2 | 12.8 | 5.0 | 426.8 | 1.17 | 0.05 | 1.09 | -0.96 | -0.89 | 3.21 | |
| E,4.1-5 | 22.3 | 20.8 | 12.5 | 7.0 | 18.0 | 18.0 | 9.6 | 39.1 | 10.6 | 5.0 | 426.8 | 1.31 | 0.06 | 1.25 | -1.16 | -1.07 | 3.65 | |
| D,5-6 | 32.0 | 30.5 | 10.5 | 7.0 | 18.0 | 18.0 | 12.6 | 23.7 | 11.6 | 5.0 | 100.0 | 1.09 | 0.05 | 1.05 | -1.07 | -0.99 | 3.06 | |
| D,6-7 | 32.0 | 30.5 | 12.5 | 7.0 | 18.0 | 18.0 | 12.2 | 22.9 | 12.4 | 5.0 | 100.0 | 1.27 | 0.06 | 1.25 | -1.07 | -0.99 | 3.60 | |
| D,7-8 | 32.0 | 30.5 | 7.5 | 7.0 | 18.0 | 18.0 | 10.9 | 23.9 | 13.4 | 5.0 | 100.0 | 0.83 | 0.04 | 0.75 | -0.69 | -0.64 | 2.24 | |
| D,8-8.5 | 13.6 | 12.1 | 7.5 | 7.0 | 18.0 | 18.0 | 5.5 | 52.1 | 33.2 | 5.0 | 100.0 | 0.83 | 0.04 | 0.75 | -0.78 | -0.72 | 2.24 | |
| F,2.1,-3.1 | 26.8 | 25.3 | 9.6 | 7.0 | 18.0 | 18.0 | 14.9 | 21.8 | 10.9 | 5.0 | 426.8 | 1.05 | 0.05 | 0.96 | -0.92 | -0.85 | 2.86 | |
| F,3.1-3.8 | 27.2 | 25.7 | 9.6 | 7.0 | 18.0 | 18.0 | 11.3 | 22.6 | 13.7 | 5.0 | 426.8 | 1.05 | 0.05 | 0.96 | -1.20 | -1.10 | 2.86 | |
| F,3.8-4.1 | 13.3 | 11.8 | 9.6 | 7.0 | 18.0 | 18.0 | 6.7 | -166.0 | 8.8 | 5.0 | 100.0 | 1.05 | 0.05 | 0.96 | -1.21 | -1.11 | 2.86 | |
| F,4.1-4.9 | 23.6 | 22.1 | 9.6 | 7.0 | 18.0 | 18.0 | 13.0 | 20.9 | 12.9 | 5.0 | 426.8 | 1.05 | 0.05 | 0.96 | -1.59 | -1.47 | 2.86 | |
| F,4.9,5.5 | 16.8 | 15.3 | 9.6 | 7.0 | 18.0 | 18.0 | 13.9 | 112.6 | 6.2 | 5.0 | 100.0 | 1.05 | 0.05 | 0.96 | -1.02 | -0.94 | 2.86 | |
| F,5.5,6.6 | 35.0 | 33.5 | 9.9 | 7.0 | 18.0 | 18.0 | 12.4 | 20.4 | 14.0 | 5.0 | 516.5 | 1.14 | 0.05 | 0.99 | -1.00 | -0.92 | 3.01 | |
| 1.1.F-E.5 | 13.3 | 11.8 | 12.4 | 7.0 | 18.0 | 18.0 | 19.1 | 27.8 | 7.9 | 5.0 | 0.0 | 100.0 | 1.21 | 0.06 | 1.24 | -1.04 | -0.96 | 3.51 |
| 1.1.E.5-0.A | 22.8 | 21.3 | 12.4 | 7.0 | 18.0 | 18.0 | 12.1 | 21.8 | 13.2 | 5.0 | 0.0 | 100.0 | 1.21 | 0.06 | 1.24 | -1.21 | -1.11 | 3.51 |
| 1.2.F-E.4 | 13.3 | 11.8 | 13.6 | 7.0 | 18.0 | 18.0 | 76.0 | 93.9 | 4.6 | 5.0 | 0.0 | 100.0 | 1.41 | 0.07 | 1.36 | -1.40 | -1.29 | 3.94 |
| 1.2.E.4-0.A | 26.8 | 25.3 | 19.1 | 7.0 | 18.0 | 18.0 | 12.3 | 21.0 | 13.6 | 5.0 | 0.0 | 100.0 | 1.89 | 0.10 | 1.91 | -1.31 | -1.21 | 5.43 |
| 1.8.E.4-A.1 | 26.6 | 25.6 | 18.8 | 7.0 | 12.0 | 12.0 | 16.5 | 19.8 | 11.3 | 5.0 | 0.0 | 100.0 | 1.86 | 0.09 | 1.88 | -1.33 | -1.22 | 5.34 |
| 1.8.A.1-0.A | 4.9 | 3.4 | 19.6 | 7.0 | 18.0 | 18.0 | 0.4 | -0.9 | 174.5 | 5.0 | 0.0 | 100.0 | 1.94 | 0.10 | 1.96 | -1.79 | -1.65 | 5.58 |
| 1.9.E.4-A.2 | 28.0 | 27.0 | 12.0 | 7.0 | 12.0 | 12.0 | 17.1 | 19.7 | 11.1 | 5.0 | 0.0 | 100.0 | 1.23 | 0.06 | 1.20 | -0.80 | -0.74 | 3.46 |
| 1.9.A.2-0.A | 8.0 | 6.5 | 11.0 | 7.0 | 18.0 | 18.0 | 2.6 | -14.1 | 1197.9 | 5.0 | 160.0 | 100.0 | 1.14 | 0.06 | 1.10 | -1.05 | -0.97 | 3.20 |

Figure 73

| Beam | Concrete Section Properties | | | | | | | | | | | | | | |
|-------------|-----------------------------|------------------|-------------------|-------------------|------|------|-------------------|--------------------|-----------------------|-----------------|-----|-----|------------------|---------------------|-----|
| | B | B _{eff} | H _{beam} | H _{Slab} | Span | L/H | A _{Beam} | A _{TBeam} | Y _{Centroid} | I | yt | yb | S _{Top} | S _{Bottom} | Cc |
| | in | in | in | in | ft | L/# | in ² | in ² | in | in ⁴ | in | in | in ³ | in ³ | in. |
| B,2-3 | 28 | 85.5 | 14 | 7 | 30.5 | 26.1 | 392.0 | 794.5 | 8.8 | 10478.9 | 5.2 | 8.8 | 2004.8 | 1194.4 | 1.5 |
| B,3-4 | 28 | 85.5 | 14 | 7 | 30.5 | 26.1 | 392.0 | 794.5 | 8.8 | 10478.9 | 5.2 | 8.8 | 2004.8 | 1194.4 | 1.5 |
| B,4-5 | 28 | 85.5 | 14 | 7 | 30.5 | 26.1 | 392.0 | 794.5 | 8.8 | 10478.9 | 5.2 | 8.8 | 2004.8 | 1194.4 | 1.5 |
| B,5-6 | 28 | 85.5 | 14 | 7 | 30.5 | 26.1 | 392.0 | 794.5 | 8.8 | 10478.9 | 5.2 | 8.8 | 2004.8 | 1194.4 | 1.5 |
| B,6-7 | 28 | 85.5 | 14 | 7 | 30.5 | 26.1 | 392.0 | 794.5 | 8.8 | 10478.9 | 5.2 | 8.8 | 2004.8 | 1194.4 | 1.5 |
| B,7-8 | 28 | 85.5 | 14 | 7 | 30.5 | 26.1 | 392.0 | 794.5 | 8.8 | 10478.9 | 5.2 | 8.8 | 2004.8 | 1194.4 | 1.5 |
| B,8-9 | 28 | 69.8 | 14 | 7 | 25.3 | 21.6 | 392.0 | 684.3 | 8.5 | 9647.0 | 5.5 | 8.5 | 1752.4 | 1135.6 | 1.5 |
| | | 0.0 | | | | | | | | | | | | | 1.5 |
| C,2-3 | 40 | 88.1 | 14 | 7 | 31.4 | 26.9 | 560.0 | 896.6 | 8.3 | 13096.1 | 5.7 | 8.3 | 2303.2 | 1575.2 | 1.5 |
| C,3-4 | 28 | 88.1 | 14 | 7 | 31.4 | 26.9 | 392.0 | 812.6 | 8.8 | 10605.3 | 5.2 | 8.8 | 2044.0 | 1203.6 | 1.5 |
| C,4-5 | 28 | 88.1 | 14 | 7 | 31.4 | 26.9 | 392.0 | 812.6 | 8.8 | 10605.3 | 5.2 | 8.8 | 2044.0 | 1203.6 | 1.5 |
| C,5-6 | 28 | 88.1 | 14 | 7 | 31.4 | 26.9 | 392.0 | 812.6 | 8.8 | 10605.3 | 5.2 | 8.8 | 2044.0 | 1203.6 | 1.5 |
| C,6-7 | 28 | 88.1 | 14 | 7 | 31.4 | 26.9 | 392.0 | 812.6 | 8.8 | 10605.3 | 5.2 | 8.8 | 2044.0 | 1203.6 | 1.5 |
| C,7-8 | 28 | 88.1 | 14 | 7 | 31.4 | 26.9 | 392.0 | 812.6 | 8.8 | 10605.3 | 5.2 | 8.8 | 2044.0 | 1203.6 | 1.5 |
| C,8-9 | 28 | 35.0 | 14 | 7 | 13.7 | 11.7 | 392.0 | 441.1 | 7.4 | 7137.3 | 6.6 | 7.4 | 1079.7 | 965.9 | 1.5 |
| | | 0.0 | | | | | | | | | | | | | 1.5 |
| E,3-4.1 | 30 | 95.0 | 14 | 7 | 39.0 | 33.4 | 420.0 | 875.0 | 8.8 | 11393.3 | 5.2 | 8.8 | 2199.5 | 1291.8 | 1.5 |
| E,4.1-5 | 30 | 62.5 | 14 | 7 | 22.3 | 19.1 | 420.0 | 647.4 | 8.2 | 9596.0 | 5.8 | 8.2 | 1662.9 | 1166.1 | 1.5 |
| D,5-6 | 24 | 91.5 | 14 | 7 | 32.0 | 27.4 | 336.0 | 808.5 | 9.0 | 9822.8 | 5.0 | 9.0 | 1982.6 | 1085.9 | 1.5 |
| D,6-7 | 24 | 91.5 | 14 | 7 | 32.0 | 27.4 | 336.0 | 808.5 | 9.0 | 9822.8 | 5.0 | 9.0 | 1982.6 | 1085.9 | 1.5 |
| D,7-8 | 24 | 30.5 | 14 | 7 | 32.0 | 27.4 | 336.0 | 381.5 | 7.4 | 6164.7 | 6.6 | 7.4 | 936.5 | 831.1 | 1.5 |
| D,8-8.5 | 24 | 24.0 | 14 | 7 | 13.6 | 11.6 | 336.0 | 336.0 | 7.0 | 5488.0 | 7.0 | 7.0 | 784.0 | 784.0 | 1.5 |
| | | 0.0 | | | | | | | | | | | | | 1.5 |
| F,2.1,-3.1 | 18 | 25.3 | 18 | 7 | 26.8 | 17.9 | 324.0 | 375.3 | 9.8 | 10298.1 | 8.2 | 9.8 | 1248.6 | 1056.0 | 1.5 |
| F,3.1-3.8 | 18 | 25.7 | 18 | 7 | 27.2 | 18.1 | 324.0 | 378.0 | 9.8 | 10367.5 | 8.2 | 9.8 | 1262.1 | 1059.5 | 1.5 |
| F,3.8-4.1 | 18 | 18.0 | 18 | 7 | 13.3 | 8.8 | 324.0 | 324.0 | 9.0 | 8748.0 | 9.0 | 9.0 | 972.0 | 972.0 | 1.5 |
| F,4.1-4.9 | 18 | 22.1 | 18 | 7 | 23.6 | 15.7 | 324.0 | 352.6 | 9.4 | 9659.3 | 8.6 | 9.4 | 1129.2 | 1022.6 | 1.5 |
| F4.9,5.5 | 18 | 18.0 | 18 | 7 | 16.8 | 11.2 | 324.0 | 324.0 | 9.0 | 8748.0 | 9.0 | 9.0 | 972.0 | 972.0 | 1.5 |
| F,5.5,6.6 | 24 | 33.5 | 18 | 7 | 35.0 | 23.3 | 432.0 | 498.5 | 9.7 | 13678.8 | 8.3 | 9.7 | 1654.8 | 1405.3 | 1.5 |
| | | | | | | | | | | | | | | | |
| 1.1,F-E.5 | 18 | 35.3 | 14 | 7 | 13.3 | 11.4 | 252.0 | 372.8 | 8.1 | 5609.1 | 5.9 | 8.1 | 956.2 | 689.6 | 1.5 |
| 1.1,E.5-0.A | 18 | 63.8 | 14 | 7 | 22.8 | 19.5 | 252.0 | 572.3 | 9.0 | 7151.3 | 5.0 | 9.0 | 1418.5 | 798.2 | 1.5 |
| | | | | | | | | | | | | | | | |
| 1.2,F-E.4 | 30 | 35.3 | 14 | 7 | 13.3 | 11.4 | 420.0 | 456.8 | 7.3 | 7424.0 | 6.7 | 7.3 | 1105.0 | 1019.6 | 1.5 |
| 1.2,E.4-0.A | 30 | 75.8 | 14 | 7 | 26.8 | 22.9 | 420.0 | 740.3 | 8.5 | 10393.5 | 5.5 | 8.5 | 1894.6 | 1220.7 | 1.5 |
| | | | | | | | | | | | | | | | |
| 1.8,E.4-A.1 | 30 | 76.8 | 14 | 7 | 26.6 | 22.8 | 420.0 | 747.3 | 8.5 | 10449.5 | 5.5 | 8.5 | 1911.3 | 1224.6 | 1.5 |
| 1.8,A.1-0.A | 30 | 30.0 | 14 | 7 | 4.9 | 4.2 | 420.0 | 420.0 | 7.0 | 6860.0 | 7.0 | 7.0 | 980.0 | 980.0 | 1.5 |
| | | | | | | | | | | | | | | | |
| 1.9,E.4-A.2 | 24 | 81.0 | 14 | 7 | 28.0 | 24.0 | 336.0 | 735.0 | 8.9 | 9351.7 | 5.1 | 8.9 | 1833.7 | 1050.7 | 1.5 |
| 1.9,A.2-0.A | 24 | 24.0 | 14 | 7 | 8.0 | 6.9 | 336.0 | 336.0 | 7.0 | 5488.0 | 7.0 | 7.0 | 784.0 | 784.0 | 1.5 |

Figure 74

| Post Tensioning Tendon Properties | | | | | | | | | | | | | | | | |
|-----------------------------------|------------------------------|-----------------|---------------|---------------|----------------|---------|-------------|--------|----------|--------------------------|---------|---------|---------------------|--------|---------------------|---------|
| Beam | Individual Tendon Properties | | | | Tendon Profile | | | | | Banded Tendon Properties | | | Balancing Load | | | |
| | ϕp | A_p | P_i /tendon | P_e /tendon | Support (A) | Midspan | Support (B) | ρ | δ | # of Tendons | P_i | P | W_{Bal} @ Jacking | | W_{Bal} @ Service | |
| | in | in ² | k/tendon | k/tendon | in | in | in | in | in | | kips | kips | k/ft | % DL | k/ft | % DL |
| B,2-3 | 0.5 | 0.153 | 28.92 | 26.62 | 9.00 | 2.25 | 11.75 | 14.3 | 8.1 | 6 | 173.502 | 159.732 | -1.01 | 86% | -0.9 | 75.42% |
| B,3-4 | 0.5 | 0.153 | 28.92 | 26.62 | 11.75 | 3.00 | 11.75 | 13.3 | 8.8 | 6 | 173.502 | 159.732 | -1.09 | 85% | -1.0 | 74.68% |
| B,4-5 | 0.5 | 0.153 | 28.92 | 26.62 | 11.75 | 2.25 | 11.75 | 12.2 | 9.5 | 6 | 173.502 | 159.732 | -1.18 | 89% | -1.1 | 78.38% |
| B,5-6 | 0.5 | 0.153 | 28.92 | 26.62 | 11.75 | 2.25 | 11.75 | 12.2 | 9.5 | 6 | 173.502 | 159.732 | -1.18 | 89% | -1.1 | 78.38% |
| B,6-7 | 0.5 | 0.153 | 28.92 | 26.62 | 11.75 | 3.00 | 11.75 | 13.3 | 8.8 | 6 | 173.502 | 159.732 | -1.09 | 85% | -1.0 | 74.68% |
| B,7-8 | 0.5 | 0.153 | 28.92 | 26.62 | 11.75 | 3.50 | 11.75 | 14.1 | 8.3 | 6 | 173.502 | 159.732 | -1.03 | 87% | -0.9 | 76.58% |
| B,8-9 | 0.5 | 0.153 | 28.92 | 26.62 | 11.75 | 2.25 | 9.00 | 9.8 | 8.1 | 6 | 173.502 | 159.732 | -1.47 | 86% | -1.4 | 75.40% |
| C,2-3 | 0.5 | 0.153 | 28.92 | 26.62 | 9.00 | 4.25 | 11.75 | 20.1 | 6.1 | 13 | 375.921 | 346.086 | -1.56 | 86% | -1.4 | 75.68% |
| C,3-4 | 0.5 | 0.153 | 28.92 | 26.62 | 11.75 | 2.25 | 11.75 | 12.9 | 9.5 | 5 | 144.585 | 133.11 | -0.93 | 83% | -0.9 | 72.93% |
| C,4-5 | 0.5 | 0.153 | 28.92 | 26.62 | 11.75 | 2.25 | 11.75 | 12.9 | 9.5 | 5 | 144.585 | 133.11 | -0.93 | 72% | -0.9 | 63.01% |
| C,5-6 | 0.5 | 0.153 | 28.92 | 26.62 | 11.75 | 2.25 | 11.75 | 12.9 | 9.5 | 6 | 173.502 | 159.732 | -1.12 | 74% | -1.0 | 64.78% |
| C,6-7 | 0.5 | 0.153 | 28.92 | 26.62 | 11.75 | 2.25 | 11.75 | 12.9 | 9.5 | 6 | 173.502 | 159.732 | -1.12 | 74% | -1.0 | 64.78% |
| C,7-8 | 0.5 | 0.153 | 28.92 | 26.62 | 11.75 | 2.25 | 11.75 | 12.9 | 9.5 | 6 | 173.502 | 159.732 | -1.12 | 74% | -1.0 | 64.78% |
| C,8-9 | 0.5 | 0.153 | 28.92 | 26.62 | 11.75 | 8.50 | 9.00 | 12.5 | 1.9 | 6 | 173.502 | 159.732 | -1.16 | 77% | -1.1 | 67.29% |
| E,3-4.1 | 0.5 | 0.153 | 28.92 | 26.62 | 11.75 | 2.25 | 11.75 | 20.0 | 9.5 | 8 | 231.336 | 212.976 | -0.96 | 82% | -0.9 | 72.41% |
| E,4.1-5 | 0.5 | 0.153 | 28.92 | 26.62 | 11.75 | 8.00 | 11.75 | 16.6 | 3.8 | 8 | 231.336 | 212.976 | -1.16 | 88% | -1.1 | 77.66% |
| D,5-6 | 0.5 | 0.153 | 28.92 | 26.62 | 11.75 | 2.25 | 11.75 | 13.5 | 9.5 | 6 | 173.502 | 159.732 | -1.07 | 98% | -1.0 | 86.19% |
| D,6-7 | 0.5 | 0.153 | 28.92 | 26.62 | 11.75 | 2.25 | 11.75 | 13.5 | 9.5 | 6 | 173.502 | 159.732 | -1.07 | 85% | -1.0 | 74.21% |
| D,7-8 | 0.5 | 0.153 | 28.92 | 26.62 | 11.75 | 4.25 | 9.00 | 20.9 | 6.1 | 6 | 173.502 | 159.732 | -0.69 | 83% | -0.6 | 73.32% |
| D,8-8.5 | 0.5 | 0.153 | 28.92 | 26.62 | 9.00 | 7.75 | 9.00 | 18.4 | 1.3 | 6 | 173.502 | 159.732 | -0.78 | 94% | -0.7 | 83.08% |
| F,2.1,-3.1 | 0.5 | 0.153 | 28.92 | 26.62 | 10.00 | 4.25 | 15.75 | 10.4 | 8.6 | 4 | 115.668 | 106.488 | -0.92 | 88% | -0.9 | 77.55% |
| F,3.1-3.8 | 0.5 | 0.153 | 28.92 | 26.62 | 15.75 | 4.25 | 15.75 | 8.0 | 11.5 | 4 | 115.668 | 106.488 | -1.20 | 114% | -1.1 | 100.57% |
| F,3.8-4.1 | 0.5 | 0.153 | 28.92 | 26.62 | 15.75 | 13.00 | 15.75 | 8.0 | 2.8 | 4 | 115.668 | 106.488 | -1.21 | 115% | -1.1 | 101.41% |
| F,4.1-4.9 | 0.5 | 0.153 | 28.92 | 26.62 | 15.75 | 4.25 | 15.75 | 6.0 | 11.5 | 4 | 115.668 | 106.488 | -1.59 | 152% | -1.5 | 133.86% |
| F4.9,5.5 | 0.5 | 0.153 | 28.92 | 26.62 | 15.75 | 12.00 | 15.75 | 9.4 | 3.8 | 4 | 115.668 | 106.488 | -1.02 | 97% | -0.9 | 85.68% |
| F,5.5,6.6 | 0.5 | 0.153 | 28.92 | 26.62 | 15.75 | 2.25 | 10.00 | 14.4 | 10.6 | 6 | 173.502 | 159.732 | -1.00 | 88% | -0.9 | 77.72% |
| 1.1,F-E.5 | 0.5 | 0.153 | 28.92 | 26.62 | 9.00 | 8.00 | 11.75 | 9.2 | 2.4 | 4 | 115.668 | 106.488 | -1.04 | 86% | -1.0 | 75.27% |
| 1.1,E.5-0.7 | 0.5 | 0.153 | 28.92 | 26.62 | 11.75 | 2.25 | 9.00 | 8.0 | 8.1 | 4 | 115.668 | 106.488 | -1.21 | 100% | -1.1 | 87.35% |
| 1.2,F-E.4 | 0.5 | 0.153 | 28.92 | 26.62 | 9.00 | 8.25 | 11.75 | 10.3 | 2.1 | 6 | 173.502 | 159.732 | -1.40 | 99% | -1.3 | 87.37% |
| 1.2,E.4-0.7 | 0.5 | 0.153 | 28.92 | 26.62 | 11.75 | 2.25 | 9.00 | 11.0 | 8.1 | 6 | 173.502 | 159.732 | -1.31 | 70% | -1.2 | 60.95% |
| 1.8,E.4-A.1 | 0.5 | 0.153 | 28.92 | 26.62 | 9.00 | 2.25 | 11.75 | 10.9 | 8.1 | 6 | 173.502 | 159.732 | -1.33 | 72% | -1.2 | 62.69% |
| 1.8,A.1-0.7 | 0.5 | 0.153 | 28.92 | 26.62 | 11.75 | 9.00 | 7.00 | 8.1 | 0.4 | 6 | 173.502 | 159.732 | -1.79 | 93% | -1.7 | 81.21% |
| 1.9,E.4-A.2 | 0.5 | 0.153 | 28.92 | 26.62 | 9.00 | 2.25 | 11.75 | 12.1 | 8.1 | 4 | 115.668 | 106.488 | -0.80 | 65% | -0.7 | 57.26% |
| 1.9,A.2-0.7 | 0.5 | 0.153 | 28.92 | 26.62 | 11.75 | 10.00 | 10.00 | 9.1 | 0.9 | 4 | 115.668 | 106.488 | -1.05 | 92.39% | -1.0 | 81.13% |

Figure 75

| Beam | Moments due to Prestress @ Time of Jacking | | | | | | Moments due to Prestress @ Service Conditions | | | | | |
|-------------|--------------------------------------------|---------|-------------|-----------------------------|---------|-------------|-----------------------------------------------|---------|-------------|-----------------------------|---------|-------------|
| | P'e @ Jacking | | | Secondary Moments @ Jacking | | | P'e @ Service | | | Secondary Moments @ Service | | |
| | Support (A) | Midspan | Support (B) | Support (A) | Midspan | Support (B) | Support (A) | Midspan | Support (B) | Support (A) | Midspan | Support (B) |
| | k-ft | k-ft | k-ft | k-ft | k-ft | k-ft | k-ft | k-ft | k-ft | k-ft | k-ft | k-ft |
| B,2-3 | 3.28 | -94.31 | 43.04 | 60.64 | 44.22 | 27.79 | 3.02 | -86.83 | 39.63 | 55.83 | 40.71 | 25.59 |
| B,3-4 | 43.04 | -83.47 | 43.04 | 30.23 | 30.57 | 30.91 | 39.63 | -76.85 | 39.63 | 27.83 | 28.15 | 28.46 |
| B,4-5 | 43.04 | -94.31 | 43.04 | 36.74 | 36.87 | 37.00 | 39.63 | -86.83 | 39.63 | 33.82 | 33.94 | 34.07 |
| B,5-6 | 43.04 | -94.31 | 43.04 | 37.00 | 36.87 | 36.74 | 39.63 | -86.83 | 39.63 | 34.06 | 33.94 | 33.83 |
| B,6-7 | 43.04 | -83.47 | 43.04 | 30.99 | 30.53 | 30.07 | 39.63 | -76.85 | 39.63 | 28.53 | 28.11 | 27.68 |
| B,7-8 | 43.04 | -76.24 | 43.04 | 26.21 | 26.84 | 27.46 | 39.63 | -70.19 | 39.63 | 24.13 | 24.71 | 25.28 |
| B,8-9 | 47.06 | -90.29 | 7.30 | 36.13 | 29.71 | 23.28 | 43.33 | -83.13 | 6.72 | 33.27 | 27.35 | 21.43 |
| C,2-3 | 21.49 | -127.31 | 107.64 | 82.86 | 44.11 | 5.35 | 19.79 | -117.20 | 99.10 | 76.28 | 40.61 | 4.93 |
| C,3-4 | 35.41 | -79.06 | 35.41 | 33.86 | 32.37 | 30.89 | 32.60 | -72.78 | 32.60 | 31.17 | 29.80 | 28.44 |
| C,4-5 | 35.41 | -79.06 | 35.41 | 30.44 | 31.50 | 32.56 | 32.60 | -72.78 | 32.60 | 28.03 | 29.00 | 29.97 |
| C,5-6 | 42.49 | -94.87 | 42.49 | 37.04 | 37.58 | 38.13 | 39.11 | -87.34 | 39.11 | 34.10 | 34.60 | 35.10 |
| C,6-7 | 42.49 | -94.87 | 42.49 | 37.75 | 37.81 | 37.87 | 39.11 | -87.34 | 39.11 | 34.75 | 34.81 | 34.86 |
| C,7-8 | 42.49 | -94.87 | 42.49 | 39.46 | 36.85 | 34.24 | 39.11 | -87.34 | 39.11 | 36.33 | 33.93 | 31.53 |
| C,8-9 | 63.05 | 16.06 | 23.29 | -40.15 | -27.83 | -15.52 | 58.04 | 14.78 | 21.44 | -36.96 | -25.62 | -14.29 |
| E,3-4.1 | 56.48 | -126.66 | 56.48 | 58.25 | 53.06 | 47.88 | 52.00 | -116.60 | 52.00 | 53.63 | 48.85 | 44.08 |
| E,4.1-5 | 67.87 | -4.42 | 67.87 | -15.42 | -17.84 | -20.26 | 62.48 | -4.07 | 62.48 | -14.19 | -16.42 | -18.65 |
| D,5-6 | 39.10 | -98.25 | 39.10 | 39.95 | 43.59 | 47.23 | 36.00 | -90.45 | 36.00 | 36.78 | 40.13 | 43.48 |
| D,6-7 | 39.10 | -98.25 | 39.10 | 42.87 | 42.14 | 41.41 | 36.00 | -90.45 | 36.00 | 39.47 | 38.80 | 38.13 |
| D,7-8 | 62.64 | -45.80 | 22.88 | -3.58 | 10.80 | 25.18 | 57.67 | -42.16 | 21.07 | -3.30 | 9.94 | 23.18 |
| D,8-8.5 | 28.92 | 10.84 | 28.92 | -8.16 | -16.81 | -25.47 | 26.62 | 9.98 | 26.62 | -7.51 | -15.48 | -23.45 |
| F,2.1,-3.1 | 2.39 | -53.04 | 57.81 | 37.28 | 16.85 | -3.58 | 2.20 | -48.83 | 53.22 | 34.32 | 15.51 | -3.30 |
| F,3.1-3.8 | 57.49 | -53.35 | 57.49 | 12.58 | 6.47 | 0.37 | 52.93 | -49.12 | 52.93 | 11.58 | 5.96 | 0.34 |
| F,3.8-4.1 | 65.06 | 38.56 | 65.06 | -40.30 | -43.21 | -46.12 | 59.90 | 35.50 | 59.90 | -37.11 | -39.78 | -42.46 |
| F,4.1-4.9 | 60.77 | -50.08 | 60.77 | -1.07 | -0.78 | -0.48 | 55.94 | -46.11 | 55.94 | -0.99 | -0.71 | -0.44 |
| F,4.9,5.5 | 65.06 | 28.92 | 65.06 | -47.78 | -37.20 | -26.62 | 59.90 | 26.62 | 59.90 | -43.99 | -34.25 | -24.51 |
| F,5.5,6.6 | 86.99 | -108.20 | 3.85 | 3.51 | 40.08 | 76.65 | 80.08 | -99.62 | 3.54 | 3.23 | 36.90 | 70.57 |
| 1.1,F-E.5 | 8.35 | -1.29 | 34.86 | -0.82 | -8.78 | -16.74 | 7.69 | -1.19 | 32.09 | -0.75 | -8.08 | -15.41 |
| 1.1,E.5-0.A | 26.91 | -64.67 | 0.40 | 18.19 | 29.64 | 41.09 | 24.77 | -59.53 | 0.37 | 16.75 | 27.29 | 37.83 |
| 1.2,F-E.4 | 24.85 | 14.00 | 64.61 | -22.30 | -22.62 | -22.94 | 22.87 | 12.89 | 59.48 | -20.53 | -20.83 | -21.12 |
| 1.2,E.4-0.A | 46.79 | -90.57 | 7.02 | 21.19 | 37.94 | 54.69 | 43.07 | -83.38 | 6.47 | 19.51 | 34.93 | 50.35 |
| 1.8,E.4-A.1 | 6.76 | -90.84 | 46.52 | 45.85 | 38.31 | 30.78 | 6.22 | -83.63 | 42.82 | 42.21 | 35.27 | 28.34 |
| 1.8,A.1-0.A | 68.68 | 28.92 | 0.00 | -15.56 | -7.72 | 0.12 | 63.23 | 26.62 | 0.00 | -14.33 | -7.11 | 0.11 |
| 1.9,E.4-A.2 | 0.96 | -64.10 | 27.47 | 33.16 | 29.01 | 24.87 | 0.89 | -59.01 | 25.29 | 30.53 | 26.71 | 22.90 |
| 1.9,A.2-0.A | 45.79 | 28.92 | 28.92 | -28.39 | -28.63 | -28.88 | 42.15 | 26.62 | 26.62 | -26.14 | -26.36 | -26.59 |

Figure 76

| Critical Section Design Moments | | | | | | | | | | | | | | | |
|---------------------------------|-------------------|----------------------|----------------|---------------------------|---------------------------|-------------------|----------------------|----------------|---------------------------|---------------------------|-------------------|----------------------|----------------|---------------------------|---------------------------|
| Beam | Support A Moments | | | | | Midspan Moments | | | | | Support B Moments | | | | |
| | M _{Dead} | M _{Service} | M _u | M _{Bal @Jacking} | M _{Bal @Service} | M _{Dead} | M _{Service} | M _u | M _{Bal @Jacking} | M _{Bal @Service} | M _{Dead} | M _{Service} | M _u | M _{Bal @Jacking} | M _{Bal @Service} |
| | k-ft | k-ft | k-ft | k-ft | k-ft | k-ft | k-ft | k-ft | k-ft | k-ft | k-ft | k-ft | k-ft | k-ft | k-ft |
| B,2-3 | -74.51 | -148.41 | -150.42 | 63.92 | 58.85 | 41.03 | 81.72 | 154.28 | -35.20 | -32.40 | -82.57 | -164.47 | -202.98 | 70.83 | 65.21 |
| B,3-4 | -86.18 | -173.10 | -213.00 | 73.27 | 67.46 | 43.34 | 87.06 | 149.27 | -36.85 | -33.93 | -86.99 | -174.72 | -214.62 | 73.96 | 68.09 |
| B,4-5 | -89.38 | -180.09 | -216.85 | 79.78 | 73.45 | 44.84 | 90.35 | 159.70 | -40.02 | -36.85 | -89.68 | -180.69 | -217.44 | 80.04 | 73.69 |
| B,5-6 | -89.68 | -180.69 | -217.43 | 80.04 | 73.69 | 44.84 | 90.34 | 159.69 | -40.02 | -36.84 | -89.39 | -180.10 | -216.86 | 79.78 | 73.45 |
| B,6-7 | -87.08 | -174.90 | -214.80 | 74.03 | 68.16 | 43.39 | 87.16 | 149.37 | -36.89 | -33.96 | -85.99 | -172.72 | -212.62 | 73.11 | 67.31 |
| B,7-8 | -79.50 | -158.36 | -195.94 | 69.25 | 63.75 | 39.35 | 78.38 | 133.63 | -34.27 | -31.55 | -80.94 | -161.22 | -198.77 | 70.50 | 64.91 |
| B,8-9 | -96.72 | -198.95 | -244.41 | 83.20 | 76.60 | 49.65 | 102.13 | 169.90 | -42.71 | -39.32 | -35.55 | -73.14 | -80.64 | 30.58 | 28.16 |
| C,2-3 | -121.14 | -243.11 | -261.92 | 104.35 | 96.07 | 69.08 | 138.64 | 233.47 | -59.51 | -54.78 | -131.18 | -263.25 | -361.29 | 113.00 | 104.03 |
| C,3-4 | -83.53 | -165.54 | -198.72 | 69.26 | 63.76 | 39.26 | 77.80 | 137.85 | -32.55 | -29.97 | -79.95 | -158.44 | -191.60 | 66.29 | 61.03 |
| C,4-5 | -91.79 | -184.61 | -228.86 | 65.85 | 60.62 | 46.59 | 93.70 | 159.39 | -33.42 | -30.77 | -94.74 | -190.54 | -235.17 | 67.96 | 62.57 |
| C,5-6 | -107.69 | -219.49 | -271.87 | 79.53 | 73.22 | 54.60 | 111.29 | 189.74 | -40.32 | -37.12 | -109.16 | -222.47 | -275.03 | 80.61 | 74.21 |
| C,6-7 | -108.65 | -221.43 | -273.93 | 80.24 | 73.87 | 54.30 | 110.67 | 189.08 | -40.10 | -36.92 | -108.81 | -221.77 | -274.29 | 80.36 | 73.98 |
| C,7-8 | -110.97 | -226.17 | -278.96 | 81.95 | 75.45 | 55.59 | 113.30 | 191.88 | -41.05 | -37.80 | -103.90 | -211.76 | -263.67 | 76.73 | 70.64 |
| C,8-9 | -29.86 | -60.85 | -121.79 | 22.90 | 21.08 | 5.77 | 11.75 | -9.24 | -4.42 | -4.07 | -10.12 | -20.63 | -43.05 | 7.77 | 7.15 |
| E,3-4.1 | -139.40 | -275.40 | -328.67 | 114.73 | 105.63 | 69.89 | 138.08 | 240.53 | -57.53 | -52.96 | -126.79 | -250.51 | -303.66 | 104.36 | 96.08 |
| E,4.1-5 | -59.35 | -118.71 | -179.25 | 52.45 | 48.29 | 14.57 | 29.14 | 24.10 | -12.88 | -11.85 | -53.87 | -107.75 | -168.47 | 47.61 | 43.83 |
| D,5-6 | -80.57 | -161.79 | -188.31 | 79.05 | 72.78 | 42.90 | 86.14 | 159.97 | -42.09 | -38.75 | -88.00 | -176.70 | -202.35 | 86.34 | 79.48 |
| D,6-7 | -96.92 | -197.18 | -235.35 | 81.97 | 75.47 | 51.47 | 104.72 | 184.75 | -43.54 | -40.08 | -95.20 | -193.68 | -231.80 | 80.52 | 74.13 |
| D,7-8 | -70.96 | -138.19 | -194.73 | 59.06 | 54.37 | 32.31 | 62.91 | 97.10 | -26.89 | -24.76 | -57.74 | -112.44 | -132.59 | 48.06 | 44.25 |
| D,8-8.5 | -22.01 | -42.86 | -66.89 | 20.76 | 19.11 | 2.33 | 4.53 | -9.20 | -2.20 | -2.02 | -3.66 | -7.12 | -33.31 | 3.45 | 3.18 |
| F,2.1,-3.1 | -45.02 | -88.42 | -88.32 | 39.66 | 36.52 | 30.82 | 60.53 | 99.46 | -27.15 | -25.00 | -61.56 | -120.89 | -170.97 | 54.23 | 49.93 |
| F,3.1-3.8 | -61.33 | -120.45 | -155.48 | 70.07 | 64.51 | 30.63 | 60.15 | 89.39 | -34.99 | -32.22 | -50.64 | -99.46 | -137.61 | 57.86 | 53.27 |
| F,3.8-4.1 | -21.49 | -42.21 | -95.65 | 24.76 | 22.79 | -0.87 | -1.71 | -42.16 | 1.00 | 0.92 | -16.44 | -32.29 | -87.24 | 18.94 | 17.44 |
| F,4.1-4.9 | -39.25 | -77.09 | -107.91 | 59.69 | 54.96 | 24.46 | 48.05 | 65.93 | -37.21 | -34.25 | -39.64 | -77.85 | -108.42 | 60.29 | 55.50 |
| F,4.9,5.5 | -17.75 | -34.87 | -92.35 | 17.28 | 15.91 | 2.19 | 4.30 | -28.29 | -2.13 | -1.96 | -39.49 | -77.56 | -132.09 | 38.44 | 35.39 |
| F,5.5,6.6 | -102.75 | -196.27 | -267.93 | 90.49 | 83.31 | 62.72 | 119.81 | 202.42 | -55.24 | -50.85 | -91.40 | -174.60 | -170.65 | 80.50 | 74.11 |
| 1.1,F-E.5 | -8.77 | -18.15 | -26.11 | 7.53 | 6.93 | 6.02 | 12.47 | 9.34 | -5.18 | -4.77 | -21.09 | -43.66 | -76.40 | 18.12 | 16.68 |
| 1.1,E.5-0,A | -45.23 | -93.63 | -114.05 | 45.09 | 41.52 | 25.11 | 51.99 | 99.91 | -25.04 | -23.05 | -41.61 | -86.14 | -82.50 | 41.49 | 38.19 |
| 1.2,F-E.4 | -2.56 | -5.15 | -27.70 | 2.54 | 2.34 | 2.07 | 4.16 | -15.03 | -2.06 | -1.89 | -41.88 | -84.33 | -138.48 | 41.66 | 38.36 |
| 1.2,E.4-0,A | -97.75 | -201.46 | -261.75 | 67.98 | 62.58 | 57.26 | 118.02 | 199.70 | -39.82 | -36.66 | -88.74 | -182.90 | -205.00 | 61.72 | 56.82 |
| 1.8,E.4-A.1 | -73.55 | -151.42 | -169.16 | 52.60 | 48.43 | 61.31 | 126.23 | 211.49 | -43.85 | -40.37 | -108.07 | -222.49 | -282.25 | 77.29 | 71.16 |
| 1.8,A.1-0,A | -57.31 | -118.31 | -179.53 | 53.12 | 48.90 | -25.89 | -53.46 | -81.76 | 24.00 | 22.10 | -0.13 | -0.27 | -0.26 | 0.12 | 0.11 |
| 1.9,E.4-A.2 | -52.30 | -106.10 | -117.29 | 34.12 | 31.41 | 45.36 | 92.01 | 154.90 | -29.59 | -27.24 | -80.23 | -162.76 | -203.85 | 52.34 | 48.19 |
| 1.9,A.2-0,A | -18.83 | -37.96 | -78.98 | 17.40 | 16.02 | -3.41 | -6.87 | -35.93 | 3.15 | 2.90 | -0.04 | -0.08 | -26.70 | 0.04 | 0.03 |

Figure 77

| Beam | Stress Limits | | | | Axial Stress | | Support A Stresses | | | | Midspan Stresses | | | | Support B Stresses | | | | | |
|-------------|---------------|---------------|---------------|---------------|---------------|-----|--------------------|---------------|---------------|------------|------------------|---------------|---------------|------------|--------------------|---------------|---------------|------------|------------|-----|
| | σ_{ci} | σ_{ci} | σ_{ci} | σ_{ci} | σ_{ca} | P/A | P/A | σ_{ti} | σ_{bi} | σ_t | σ_b | σ_{ti} | σ_{bi} | σ_t | σ_b | σ_{ti} | σ_{bi} | σ_t | σ_b | |
| | psi | psi | psi | psi | psi | psi | psi | psi | psi | psi | psi | psi | psi | psi | psi | psi | psi | psi | psi | psi |
| B,2-3 | 164 | -1800 | 930 | 581 | -3600 | 218 | 201 | -155 | -325 | 335 | -1101 | -253 | -160 | -496 | 294 | -148 | -336 | 393 | -1198 | |
| B,3-4 | 164 | -1800 | 930 | 581 | -3600 | 218 | 201 | -141 | -348 | 431 | -1262 | -257 | -153 | -519 | 333 | -140 | -349 | 437 | -1272 | |
| B,4-5 | 164 | -1800 | 930 | 581 | -3600 | 218 | 201 | -161 | -315 | 437 | -1272 | -247 | -170 | -521 | 336 | -161 | -315 | 439 | -1276 | |
| B,5-6 | 164 | -1800 | 930 | 581 | -3600 | 218 | 201 | -161 | -315 | 439 | -1276 | -247 | -170 | -521 | 336 | -161 | -315 | 437 | -1273 | |
| B,6-7 | 164 | -1800 | 930 | 581 | -3600 | 218 | 201 | -140 | -349 | 438 | -1273 | -257 | -153 | -519 | 333 | -141 | -348 | 430 | -1260 | |
| B,7-8 | 164 | -1800 | 930 | 581 | -3600 | 218 | 201 | -157 | -321 | 365 | -1151 | -249 | -167 | -481 | 269 | -156 | -323 | 375 | -1169 | |
| B,8-9 | 164 | -1800 | 930 | 581 | -3600 | 254 | 233 | -161 | -396 | 604 | -1526 | -301 | -180 | -664 | 430 | -220 | -306 | 75 | -709 | |
| | | | | 0 | | | | | | | | | | | | | | | | |
| C,2-3 | 164 | -1800 | 930 | 581 | -3600 | 419 | 386 | -332 | -547 | 380 | -1506 | -469 | -346 | -823 | 253 | -325 | -558 | 444 | -1599 | |
| C,3-4 | 164 | -1800 | 930 | 581 | -3600 | 178 | 164 | -94 | -320 | 434 | -1179 | -217 | -111 | -445 | 313 | -98 | -314 | 408 | -1135 | |
| C,4-5 | 164 | -1800 | 930 | 581 | -3600 | 178 | 164 | -26 | -437 | 564 | -1400 | -255 | -47 | -533 | 464 | -21 | -445 | 587 | -1440 | |
| C,5-6 | 164 | -1800 | 930 | 581 | -3600 | 214 | 197 | -48 | -494 | 662 | -1655 | -297 | -71 | -632 | 543 | -46 | -498 | 674 | -1675 | |
| C,6-7 | 164 | -1800 | 930 | 581 | -3600 | 214 | 197 | -47 | -497 | 670 | -1668 | -297 | -72 | -630 | 539 | -46 | -497 | 671 | -1670 | |
| C,7-8 | 164 | -1800 | 930 | 581 | -3600 | 214 | 197 | -43 | -503 | 688 | -1699 | -299 | -69 | -640 | 556 | -54 | -484 | 632 | -1604 | |
| C,8-9 | 164 | -1800 | 930 | 581 | -3600 | 393 | 362 | -316 | -480 | 80 | -856 | -408 | -377 | -448 | -267 | -367 | -423 | -212 | -530 | |
| E,3-4.1 | 164 | -1800 | 930 | 581 | -3600 | 264 | 243 | -130 | -493 | 683 | -1821 | -332 | -150 | -708 | 547 | -142 | -473 | 599 | -1678 | |
| E,4.1-5 | 164 | -1800 | 930 | 581 | -3600 | 357 | 329 | -308 | -428 | 179 | -1054 | -370 | -340 | -454 | -151 | -312 | -422 | 132 | -987 | |
| D,5-6 | 164 | -1800 | 930 | 581 | -3600 | 215 | 198 | -205 | -231 | 341 | -1181 | -220 | -206 | -484 | 326 | -205 | -233 | 391 | -1272 | |
| D,6-7 | 164 | -1800 | 930 | 581 | -3600 | 215 | 198 | -124 | -380 | 539 | -1543 | -263 | -127 | -589 | 517 | -126 | -377 | 526 | -1519 | |
| D,7-8 | 164 | -1800 | 930 | 581 | -3600 | 455 | 419 | -302 | -627 | 655 | -1629 | -524 | -377 | -908 | 132 | -331 | -595 | 455 | -1403 | |
| D,8-8.5 | 164 | -1800 | 930 | 581 | -3600 | 516 | 475 | -497 | -536 | -112 | -839 | -518 | -514 | -514 | -437 | -513 | -520 | -415 | -536 | |
| F,2.1,-3.1 | 164 | -1800 | 930 | 581 | -3600 | 308 | 284 | -257 | -369 | 215 | -874 | -343 | -267 | -625 | 120 | -238 | -391 | 398 | -1090 | |
| F,3.1-3.8 | 164 | -1800 | 930 | 581 | -3600 | 306 | 282 | -389 | -207 | 250 | -915 | -265 | -355 | -547 | 35 | -375 | -224 | 157 | -805 | |
| F,3.8-4.1 | 164 | -1800 | 930 | 581 | -3600 | 357 | 329 | -397 | -317 | -89 | -568 | -359 | -355 | -319 | -338 | -388 | -326 | -145 | -512 | |
| F,4.1-4.9 | 164 | -1800 | 930 | 581 | -3600 | 328 | 302 | -545 | -88 | -67 | -562 | -193 | -478 | -449 | -140 | -547 | -86 | -64 | -564 | |
| F,4.9,5.5 | 164 | -1800 | 930 | 581 | -3600 | 357 | 329 | -351 | -363 | -95 | -563 | -358 | -356 | -358 | -300 | -344 | -370 | 192 | -849 | |
| F,5.5,6.6 | 164 | -1800 | 930 | 581 | -3600 | 348 | 320 | -259 | -453 | 499 | -1285 | -402 | -284 | -820 | 268 | -269 | -441 | 408 | -1178 | |
| 1.1,F-E.5 | 164 | -1800 | 930 | 581 | -3600 | 310 | 286 | -295 | -332 | -145 | -481 | -321 | -296 | -382 | -152 | -273 | -362 | 53 | -755 | |
| 1.1,E.5-0.A | 164 | -1800 | 930 | 581 | -3600 | 202 | 186 | -201 | -204 | 255 | -969 | -203 | -201 | -431 | 249 | -201 | -204 | 219 | -907 | |
| 1.2,F-E.4 | 164 | -1800 | 930 | 581 | -3600 | 380 | 350 | -380 | -380 | -319 | -383 | -380 | -380 | -374 | -323 | -378 | -382 | 149 | -891 | |
| 1.2,E.4-0.A | 164 | -1800 | 930 | 581 | -3600 | 234 | 216 | -46 | -527 | 664 | -1581 | -345 | -63 | -731 | 584 | -63 | -500 | 583 | -1455 | |
| 1.8,E.4-A.1 | 164 | -1800 | 930 | 581 | -3600 | 232 | 214 | -101 | -437 | 433 | -1223 | -342 | -61 | -753 | 628 | -39 | -534 | 736 | -1697 | |
| 1.8,A.1-0.A | 164 | -1800 | 930 | 581 | -3600 | 413 | 380 | -362 | -464 | 470 | -1230 | -390 | -436 | 4 | -764 | -413 | -413 | -378 | -382 | |
| 1.9,E.4-A.2 | 164 | -1800 | 930 | 581 | -3600 | 157 | 145 | -38 | -365 | 344 | -998 | -261 | 23 | -569 | 595 | 25 | -476 | 605 | -1453 | |
| 1.9,A.2-0.A | 164 | -1800 | 930 | 581 | -3600 | 344 | 317 | -322 | -366 | 19 | -653 | -340 | -348 | -256 | -378 | -344 | -344 | -316 | -318 | |

Figure 78

The cells highlighted in yellow represent locations where tensile stresses exceed $7.5 \cdot \sqrt{f'c}$ but are less than $12 \cdot \sqrt{f'c}$ and are thus assumed to be in transition between uncracked and cracked behavior. This condition is considered acceptable in post tensioned beams but not in post tensioned slabs. The cell highlighted in red represents a net axial load at jacking of P/A greater than 500psi. There is no code provision limiting the maximum allowable net compressive stress, however, a common standard of practice is to avoid having net axial stresses in beams in excess of 500psi except in isolated areas, the case in this situation.

Appendix B Construction Management

| NEW DESIGN COST ESTIMATE | | | | | | | | | | | | |
|----------------------------------------------------------------------------------------------------------------------------------------------------------------------------------|----------|------|------------|---------|-----------|----------|-------------|-------------|------------|----------------|------------|------------------|
| Description | Quantity | Unit | Unit Costs | | | | | Total Costs | | | | |
| | | | Material | Labor | Equipment | Total | Total O & P | Ext. Mat. | Ext. Labor | Ext. Equipment | Ext. Total | Ext. Total O & P |
| C.I.P. concrete forms, beams and girders, interior, plywood, 24" wide, 2 use, includes shoring, erecting, bracing, stripping and cleaning | 12685 | SFCA | \$1.52 | \$3.66 | \$0.00 | \$5.18 | \$7.38 | \$19,281 | \$46,426 | \$0 | \$65,707 | \$93,613 |
| C.I.P. concrete forms, elevated slab, flat plate, plywood, to 15' high, 2 use, includes shoring, erecting, bracing, stripping and cleaning | 40104 | S.F. | \$2.42 | \$2.57 | \$0.00 | \$4.99 | \$6.64 | \$97,051 | \$103,066 | \$0 | \$200,117 | \$266,288 |
| C.I.P. concrete forms, column, square, plywood, 16" x 16", 2 use, includes erecting, bracing, stripping and cleaning | 6580 | SFCA | \$1.16 | \$4.05 | \$0.00 | \$5.21 | \$7.54 | \$7,633 | \$26,649 | \$0 | \$34,282 | \$49,613 |
| C.I.P. concrete forms, column, square, plywood, 24" x 24", 2 use, includes erecting, bracing, stripping and cleaning | 5264 | SFCA | \$1.33 | \$4.02 | \$0.00 | \$5.35 | \$7.70 | \$7,001 | \$21,161 | \$0 | \$28,162 | \$40,532 |
| C.I.P. concrete forms, wall, job built, plywood, 8 to 16' high, 2 use, includes erecting, bracing, stripping and cleaning | 6374 | SFCA | \$1.30 | \$3.87 | \$0.00 | \$5.17 | \$7.45 | \$8,286 | \$24,668 | \$0 | \$32,955 | \$47,488 |
| Reinforcing steel, unload and sort, add to base | 141 | Ton | \$0.00 | \$17.96 | \$7.92 | \$25.88 | \$37.32 | \$0 | \$2,532 | \$1,117 | \$3,648 | \$5,261 |
| Reinforcing steel, crane cost for handling, average, add | 141 | Ton | \$0.00 | \$19.42 | \$8.63 | \$28.05 | \$40.63 | \$0 | \$2,738 | \$1,217 | \$3,954 | \$5,728 |
| Prestressing steel, ungrouted strand, 100' span, 300 kip, post-tensioned in field | 9522 | Lb. | \$0.57 | \$0.64 | \$0.02 | \$1.23 | \$1.70 | \$5,428 | \$6,094 | \$190 | \$11,713 | \$16,188 |
| Reinforcing steel in place, Beams & Girders, #3 to #7 | 7706 | lb. | \$0.82 | \$0.32 | \$0.00 | \$1.14 | \$1.89 | \$6,319 | \$2,466 | \$0 | \$8,784 | \$14,563 |
| Reinforcing steel in place, Beams & Girders, #8 to #18 | 69350 | lb. | \$0.82 | \$0.19 | \$0.00 | \$1.01 | \$1.35 | \$56,867 | \$13,176 | \$0 | \$70,043 | \$93,622 |
| Reinforcing steel in place, Elevated slabs #4 to #7 | 135134 | lb. | \$0.85 | \$0.18 | \$0.00 | \$1.03 | \$1.39 | \$114,864 | \$24,324 | \$0 | \$139,188 | \$187,836 |
| Reinforcing steel in place, Columns, #3 to #7 | 1315 | lb. | \$0.82 | \$0.34 | \$0.00 | \$1.16 | \$1.98 | \$1,078 | \$447 | \$0 | \$1,526 | \$2,604 |
| Reinforcing steel in place, Columns, #8 to #18 | 46085 | lb. | \$0.82 | \$0.22 | \$0.00 | \$1.04 | \$1.48 | \$37,789 | \$10,139 | \$0 | \$47,928 | \$68,205 |
| Reinforcing steel in place, Walls, #3 to #7 | 11896 | | \$0.82 | \$0.17 | \$0.00 | \$0.99 | \$1.28 | \$9,755 | \$2,022 | \$0 | \$11,777 | \$15,227 |
| Reinforcing steel in place, Walls #8 to #18 | 10470 | | \$0.82 | \$0.13 | \$0.00 | \$0.95 | \$1.13 | \$8,585 | \$1,361 | \$0 | \$9,946 | \$11,831 |
| Structural concrete, ready mix, normal weight, high early, 6000 PSI, includes local aggregate, sand, Portland cement and water, delivered, excludes all additives and treatments | 1749 | C.Y. | \$155.36 | \$0.00 | \$0.00 | \$155.36 | \$170.67 | \$271,687 | \$0 | \$0 | \$271,687 | \$298,460 |
| Structural concrete, placing, beam, small, elevated, pumped, includes vibrating, excludes material | 343 | C.Y. | \$0.00 | \$22.82 | \$13.19 | \$36.01 | \$49.68 | \$0 | \$7,817 | \$4,518 | \$12,336 | \$17,019 |
| Structural concrete, placing, elevated slab, pumped, 6" to 10" thick, includes vibrating, excludes material | 1049 | C.Y. | \$0.00 | \$8.59 | \$4.95 | \$13.54 | \$18.78 | \$0 | \$9,012 | \$5,193 | \$14,205 | \$19,703 |
| Structural concrete, placing, column, square or round, pumped, 18" thick, includes vibrating, excludes material | 111 | C.Y. | \$0.00 | \$15.22 | \$8.83 | \$24.05 | \$33.14 | \$0 | \$1,693 | \$982 | \$2,676 | \$3,687 |
| Structural concrete, placing, column, square or round, pumped, 24" thick, includes vibrating, excludes material | 124 | C.Y. | \$0.00 | \$14.90 | \$8.63 | \$23.53 | \$32.30 | \$0 | \$1,854 | \$1,074 | \$2,928 | \$4,020 |
| Walls, 12" thick, pumped | 121 | C.Y. | \$0.00 | \$12.96 | \$5.13 | \$18.09 | \$26.84 | \$0 | \$1,568 | \$621 | \$2,189 | \$3,248 |
| Total | | | | | | | | \$651,623 | \$309,214 | \$14,912 | \$975,750 | \$1,264,735 |

Figure 81

| ORIGINAL DESIGN COST ESTIMATE | | | | | | | | | | | | | |
|----------------------------------------------------------------------------------------------------------------------------------------------------------------------|----------|------|------------|---------|-----------|----------|-------------|-------------|------------|----------------|-------------|------------------|--|
| Description | Quantity | Unit | Unit Costs | | | | | Total Costs | | | | | |
| | | | Material | Labor | Equipment | Total | Total O & P | Ext. Mat. | Ext. Labor | Ext. Equipment | Ext. Total | Ext. Total O & P | |
| C.I.P. concrete forms, beams and girders, interior, plywood, 24" wide, 2 use, includes shoring, erecting, bracing, stripping and cleaning | 3642 | SFCA | \$1.52 | \$3.66 | \$0.00 | \$5.18 | \$7.38 | \$5,536 | \$13,330 | \$0 | \$18,866 | \$26,878 | |
| C.I.P. concrete forms, elevated slab, flat plate, plywood, to 15' high, 2 use, includes shoring, erecting, bracing, stripping and cleaning | 44918 | S.F. | \$2.42 | \$2.57 | \$0.00 | \$4.99 | \$6.64 | \$108,702 | \$115,439 | \$0 | \$224,141 | \$298,256 | |
| C.I.P. concrete forms, column, square, plywood, 16" x 16", 2 use, includes erecting, bracing, stripping and cleaning | 6016 | SFCA | \$1.16 | \$4.05 | \$0.00 | \$5.21 | \$7.54 | \$6,979 | \$24,365 | \$0 | \$31,343 | \$45,361 | |
| C.I.P. concrete forms, column, square, plywood, 24" x 24", 2 use, includes erecting, bracing, stripping and cleaning | 4888 | SFCA | \$1.33 | \$4.02 | \$0.00 | \$5.35 | \$7.70 | \$6,501 | \$19,649 | \$0 | \$26,150 | \$37,637 | |
| C.I.P. concrete forms, wall, job built, plywood, 8 to 16' high, 2 use, includes erecting, bracing, stripping and cleaning | 15059 | SFCA | \$1.30 | \$3.87 | \$0.00 | \$5.17 | \$7.45 | \$19,577 | \$58,280 | \$0 | \$77,857 | \$112,192 | |
| Reinforcing steel, unload and sort, add to base | 211 | Ton | \$0.00 | \$17.96 | \$7.92 | \$25.88 | \$37.32 | \$0 | \$3,782 | \$1,668 | \$5,450 | \$7,859 | |
| Reinforcing steel, crane cost for handling, average, add | 211 | Ton | \$0.00 | \$19.42 | \$8.63 | \$28.05 | \$40.63 | \$0 | \$4,089 | \$1,817 | \$5,907 | \$8,556 | |
| Reinforcing steel in place, Beams & Girders, #3 to #7 | 2805 | lb. | \$0.82 | \$0.32 | \$0.00 | \$1.14 | \$1.89 | \$2,300 | \$898 | \$0 | \$3,198 | \$5,302 | |
| Reinforcing steel in place, Beams & Girders, #8 to #18 | 25247 | lb. | \$0.82 | \$0.19 | \$0.00 | \$1.01 | \$1.35 | \$20,702 | \$4,797 | \$0 | \$25,499 | \$34,083 | |
| Reinforcing steel in place, Elevated slabs #4 to #7 | 294964 | lb. | \$0.85 | \$0.18 | \$0.00 | \$1.03 | \$1.39 | \$250,719 | \$53,093 | \$0 | \$303,812 | \$409,999 | |
| Reinforcing steel in place, Columns, #3 to #7 | 974 | lb. | \$0.82 | \$0.34 | \$0.00 | \$1.16 | \$1.98 | \$798 | \$331 | \$0 | \$1,129 | \$1,928 | |
| Reinforcing steel in place, Columns, #8 to #18 | 42458 | lb. | \$0.82 | \$0.22 | \$0.00 | \$1.04 | \$1.48 | \$34,816 | \$9,341 | \$0 | \$44,156 | \$62,838 | |
| Reinforcing steel in place, Walls, #3 to #7 | 28366 | lb. | \$0.82 | \$0.17 | \$0.00 | \$0.99 | \$1.28 | \$23,260 | \$4,822 | \$0 | \$28,082 | \$36,309 | |
| Reinforcing steel in place, Walls #8 to #18 | 26335 | lb. | \$0.82 | \$0.13 | \$0.00 | \$0.95 | \$1.13 | \$21,595 | \$3,424 | \$0 | \$25,018 | \$29,759 | |
| Structural concrete, ready mix, normal weight, 5000 psi, includes local aggregate, sand, Portland cement and water, delivered, excludes all additives and treatments | 2344 | C.Y. | \$130.65 | \$0.00 | \$0.00 | \$130.65 | \$143.59 | \$306,264 | \$0 | \$0 | \$306,264 | \$336,597 | |
| Structural concrete, placing, beam, small, elevated, pumped, includes vibrating, excludes material | 142 | C.Y. | \$0.00 | \$22.82 | \$13.19 | \$36.01 | \$49.68 | \$0 | \$3,237 | \$1,871 | \$5,108 | \$7,047 | |
| Structural concrete, placing, elevated slab, pumped, over 10" thick, includes vibrating, excludes material | 1743 | C.Y. | \$0.00 | \$7.64 | \$4.40 | \$12.04 | \$16.53 | \$0 | \$13,316 | \$7,669 | \$20,985 | \$28,811 | |
| Structural concrete, placing, column, square or round, pumped, 18" thick, includes vibrating, excludes material | 101 | C.Y. | \$0.00 | \$15.22 | \$8.83 | \$24.05 | \$33.14 | \$0 | \$1,541 | \$894 | \$2,435 | \$3,355 | |
| Structural concrete, placing, column, square or round, pumped, 24" thick, includes vibrating, excludes material | 91 | C.Y. | \$0.00 | \$14.90 | \$8.63 | \$23.53 | \$32.30 | \$0 | \$1,349 | \$781 | \$2,130 | \$2,924 | |
| Walls, 12" thick, pumped | 268 | C.Y. | | \$12.96 | \$5.13 | \$18.09 | \$26.84 | | \$3,473 | \$1,375 | \$4,848 | \$7,193 | |
| Total | | | | | | | | \$807,748 | \$338,556 | \$16,075 | \$1,162,379 | \$1,502,882 | |

Figure 82

Two-Way Flat Plate Design Schedule

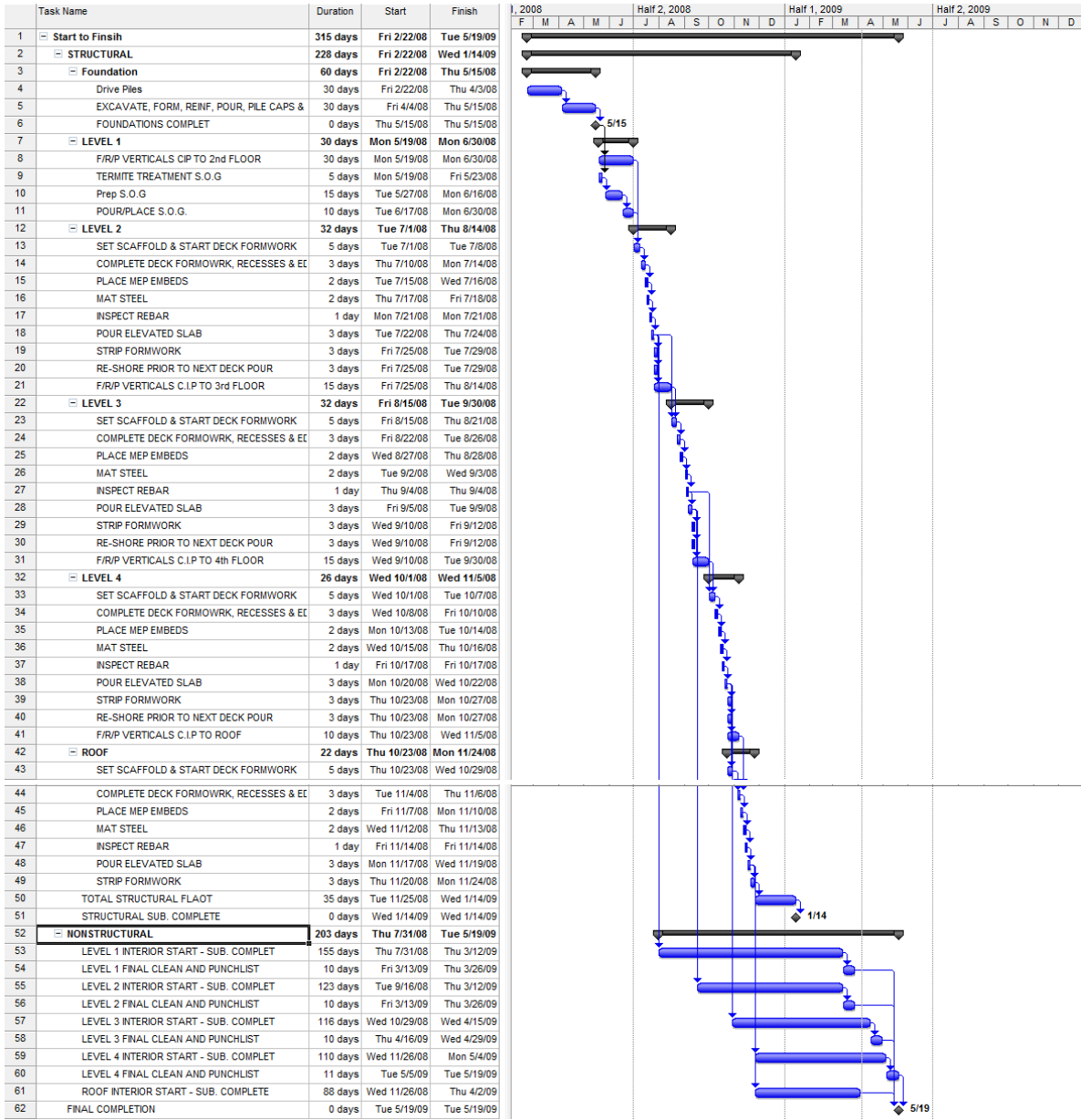

Figure 83

Post Tensioned Design Schedule Part 1

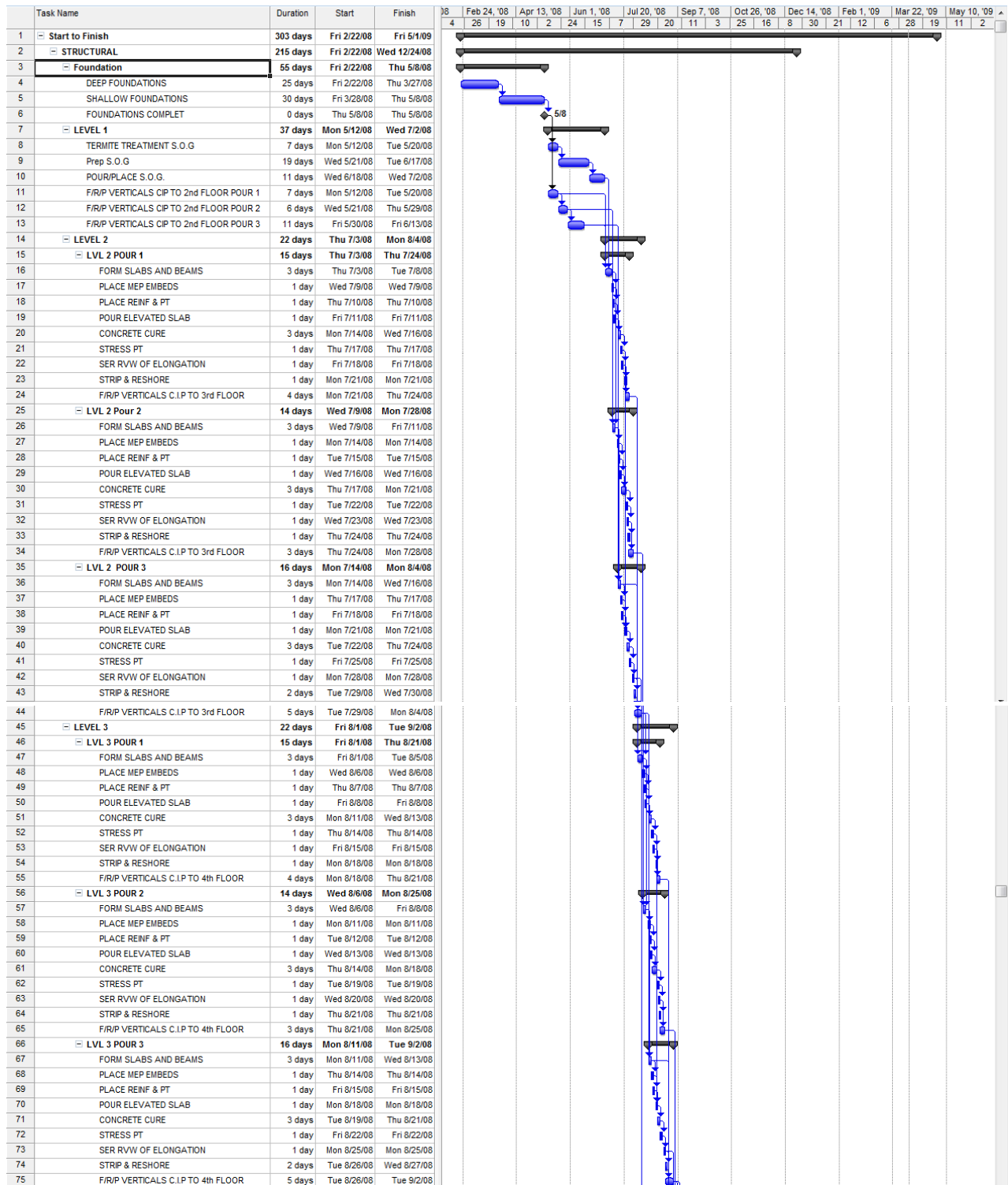

Figure 84

Post Tensioned Design Schedule Part 2

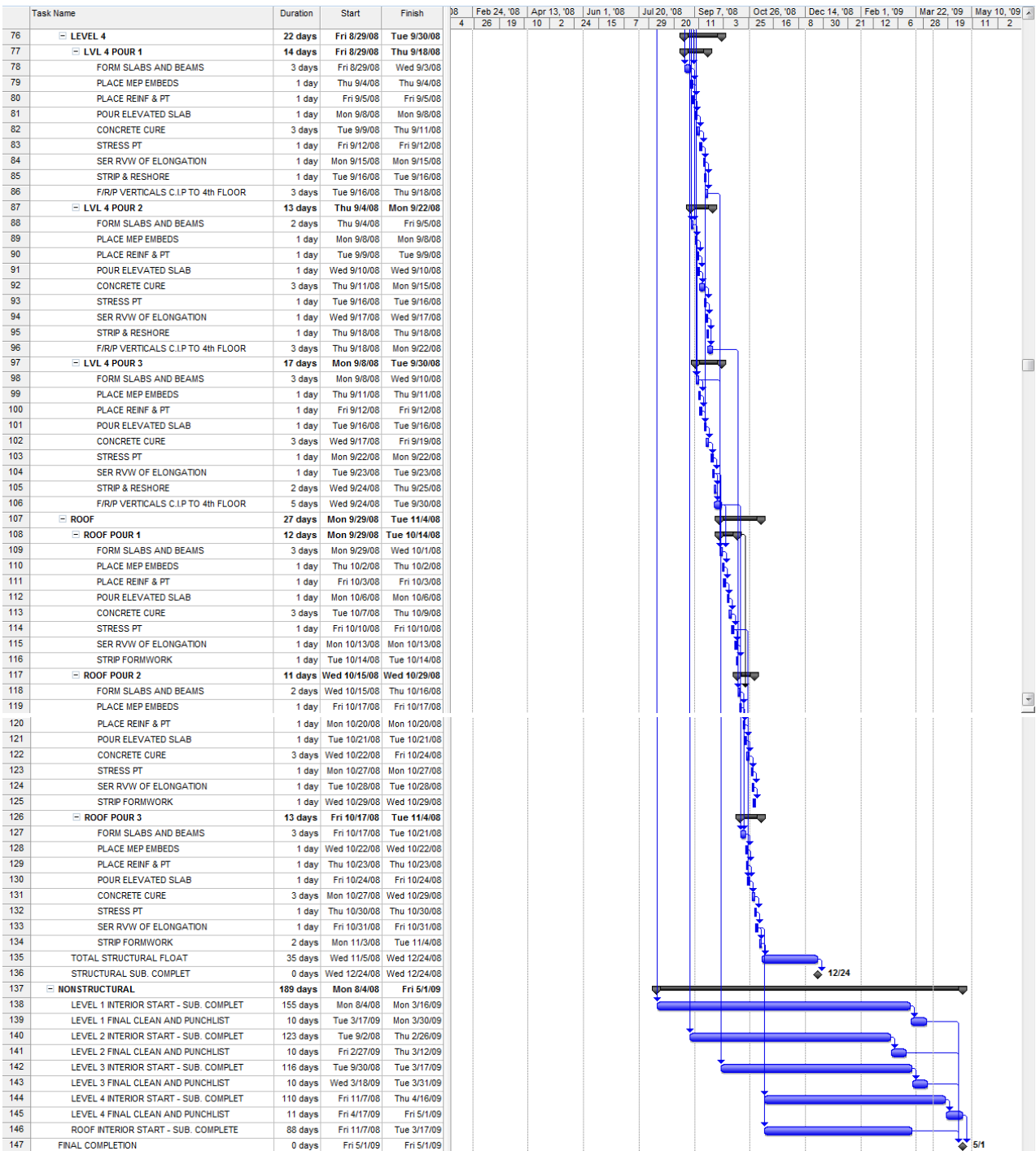

Figure 85